

# SPECIFIC PLAN

## LOYOLA CORNERS NEIGHBORHOOD COMMERCIAL CENTER



Prepared for: City of Los Altos

## LOYOLA CORNERS SPECIFIC PLAN\*

### ADDENDUM

1. Add: Dolores Street to become one-way from Fremont Avenue to Miramonte Avenue. (Phase IB)
2. Add: Provide a sidewalk for pedestrians along Dolores Street (Phase IB)
3. Add: Close Dolores Street to through traffic by creating a small mini-park at the intersection with Carob Lane (Phase II).
4. Remove: In appendix A, Table 5, Phase IB delete:  
"Removes all through traffic from Loraine Avenue."
5. Approve rezoning of parcels at 991 Dolores Street (APN 189-15-26 and APN 189-15-27) from residential to commercial with the option that if the property is developed as mixed use, the portion developed as commercial could be included in the Parking District to allow mixed commercial and residential development of the parcels. (Phase IA).
6. Approve acquisition of the parcel at 982 Dolores Street for access and parking as part of the proposed Pedestrian-Parking Plaza, with the understanding that first priority in relocation be given to potential tenants of the building (Phase IB)
7. Close Maple Lane to through traffic at the intersection of Dolores (Phase IB)

\*Loyola Corners

Specific Plan and addendum adopted by City Council Resolution #90-44 December 18, 1990.

RESOLUTION NO. 93-43

A RESOLUTION OF THE CITY COUNCIL OF THE CITY OF LOS ALTOS  
AMENDING THE LOYOLA CORNERS NEIGHBORHOOD COMMERCIAL CENTER  
SPECIFIC PLAN, POLICIES FOR SPECIFIC PARCELS.

---

WHEREAS, the State of California Government Code, Section 65453 provides for the amendment of a Specific Plan in the same manner as a General Plan; and

WHEREAS, the California Government Code, Section 65454 requires this amendment to the Loyola Corners Neighborhood Commercial Center Specific Plan to be consistent with the Los Altos General Plan; and

WHEREAS, the City Council of the City of Los Altos finds, pursuant to Government Code Section 65358, the Specific Plan amendment to be in the public interest, and finds that the actions serve to further enhance the goals and policies outlined in the Specific Plan.

NOW, THEREFORE, BE IT HEREBY RESOLVED, that the City Council of the City of Los Altos certifies that the Negative Declaration of Environmental Impact for this amendment to the Loyola Corners Neighborhood Commercial Center Specific Plan is complete, correct, adequate, and prepared pursuant to the California Environmental Quality Act, and all appropriate State and local guidelines;

BE IT FURTHER RESOLVED, that the City Council of the City of Los Altos adopts an amendment to the Loyola Corners Neighborhood Commercial Center Specific Plan making the following changes:

\*\*\*\*\*

*Policies for Specific Parcels, page 42, Part H would be changed to:*

**H. Policies for Specific Parcels**

The following policies are intended to guide land use decisions for ~~three~~ five key parcels in the Loyola Corners area:

*And, on Page 46 of the Plan, a new parcel would be added to the list:*

**SP - 5 Loyola Center, 1000 Fremont Avenue**

Location: Intersection of Fremont and Miramonte Avenues, adjacent to Foothill Expressway, kitty-corner from the Photo Drive-Up Site (see SP-3).

Assessors Parcel Number: 318-01-36

This building has been added-to several times over the years and has had exclusively office type uses, excepting approximately 2,500 ± square feet which was built as retail. The building is located at the southern most part of the Loyola Corners planning area, adjacent to Permanente Creek on the residential border.

This building is somewhat unique in that it provides all of its parking on-site and is removed by its location from the central triangle buildings by 2 major streets. Another notable aspect to the Loyola Center building is that it consists of almost entirely office space, with the exception of the retail space at the front of the building. For land use purposes, the entire building shall be considered available for office occupancy.

Further development to this property therefore should not discount the conditional expansion limitations imposed by this Specific Plan because the site is reasonably able to absorb its own parking demands within the existing parking layout.

\*\*\*\*\*

I HEREBY CERTIFY that the foregoing Resolution was duly introduced and adopted by the City Council of the City of Los Altos at a meeting thereof held on December 14, 1993.

AYES: Mayor Bruno, Councilmembers Gray, Lalliotis, Reeder and Williams.

NOES: None

ABSENT: None

Attest:

  
Marge Bruno, Mayor

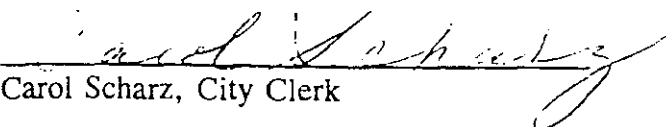
  
Carol Scharz, City Clerk

**SPECIFIC PLAN**

**Loyola Corners Neighborhood Commercial Center**

**Prepared for**

**City of Los Altos**

**November 15, 1990**

**Donald A. Woolfe and Associates  
707 Bradford St., Suite D  
Redwood City, CA 94063  
(415) 366-2533**

## **ACKNOWLEDGEMENTS**

### **City Council**

David W. Reeder, Mayor  
S. G. (Denny) Spangler, Mayor Pro Tem  
Margaret S. Bruno  
Theodore A. Laliotis  
Penelope R. Lave

### **Planning Commission**

Kristine Salmon, Chair  
Mark Srebnik, Vice Chair  
Kris Casto  
Catherine Lu  
Milt Nicholas  
Patricia Williams

### **Loyola Corners Study Advisory Committee**

Sherrill Walker, Chair  
Elie Alcheck  
Tom Andrews  
Ed Barnes  
Michele Coldiron  
Charles Halleck  
Terry Krivan  
Theodore Laliotis  
Catherine Lu  
Leon Pirofalo  
Robert Prillinger  
Greg Rivera  
Denny Spangler  
Kelly Thompson  
Patricia Williams

Bruce Bane, Staff  
Deborah Nelson, Staff

### **City Staff**

Deborah Nelson, Planning Director  
Bruce Bane, Public Works Director

### **Consultants**

Donald A. Woolfe and Associates,  
Architecture and Urban Planning  
Donald A. Woolfe AIA AICP  
Donald Skinner AICP  
Robert Harrison

Hardesty & Associates, Landscape  
Architects  
Ron Benoit, ASLA

## TABLE OF CONTENTS

<b>I BACKGROUND</b> .....	1
<b>II PURPOSE OF PLAN</b> .....	6
A. Assumptions.....	6
B. Use of the Plan .....	8
C. Relationship to General Plan and Zoning Ordinance.....	9
<b>III THE PLANNING PROCESS</b> .....	12
<b>IV THE PLAN</b> .....	14
A. Basic Strategies and Priorities .....	14
B. Land Use .....	22
C. Protection of Adjacent Residential Neighborhoods .....	24
D. Circulation .....	25
E. Parking.....	28
F. Economic Viability.....	31
G. Expansion .....	36
H. Policies for Specific Parcels .....	43
I. Utilities .....	46
J. Community Design and Beautification .....	47
<b>V IMPLEMENTATION</b> .....	68
A. Specific ACtions and Responsibilities for Action .....	68
B. Planning and Zoning Regulations .....	73
C. Estimated Costs for Specific Plan Programs.....	75
D. Recommendations for Financing and Organizing to Carry Out the Program.....	76
<b>APPENDIX A</b> - Circulation and Traffic Analysis.....	I
<b>APPENDIX B</b> - Economic Analysis .....	VIII
<b>APPENDIX C</b> - Citizen Input On Loyola Corners Study.....	XX

## INDEX OF FIGURES

Figure 1 - Location Map.....	2
Figure 2 - Planning Area.....	3
Figure 3 - Phase I Plan .....	15
Figure 4 - Phase I.....	16
Figure 5 - Trade Area Map .....	32
Figure 6 - Existing View at Fremont Avenue .....	49
Figure 7 - Proposed View at Fremont and "A" St. ....	50
Figure 8 - Existing Typical Corner .....	54
Figure 9 - Typical Corner "Bump Out" .....	55
Figure 10 - Clock Tower Plaza Plan .....	56
Figure 11 - Clock Tower Elevation .....	57
Figure 12 - Proposed Elevation at Fremont Avenue .....	59
Figure 13 - Proposed Design Details .....	61
Figure 14 - Implementation Diagram .....	79



## LOYOLA CORNERS SPECIFIC PLAN

### I BACKGROUND

**Area Description** - The Loyola Corners planning area is located in the southwesterly portion of the City of Los Altos. It is bounded on the south by Foothill Expressway (a county expressway), on the east by Permanente Creek, and on the north by a line approximately half way between Loraine and Dolores Avenues (see Fig. #1). The principal internal streets are Fremont Avenue to the south (paralleling Foothill Expressway) and Miramonte Avenue. Principal access to the area is from Foothill Expressway, Fremont Avenue, Miramonte Avenue and from across the expressway via the "A" Street bridge over the depressed portion of the expressway (see Fig. #2).

The area contains approximately 17.1 acres including:

1. Approximately 9.1 acres of commercially zoned land which currently includes 38 parcels, 23 separate property ownerships and approximately 30 businesses. Currently the commercial center contains approximately 91,000 sq. ft. of floor area including:

44,000 sq. ft. - retail

8,000 sq. ft. - retail service

28,000 sq. ft. - office

11,000 sq. ft. - vacant

91,000 sq. ft. - Total

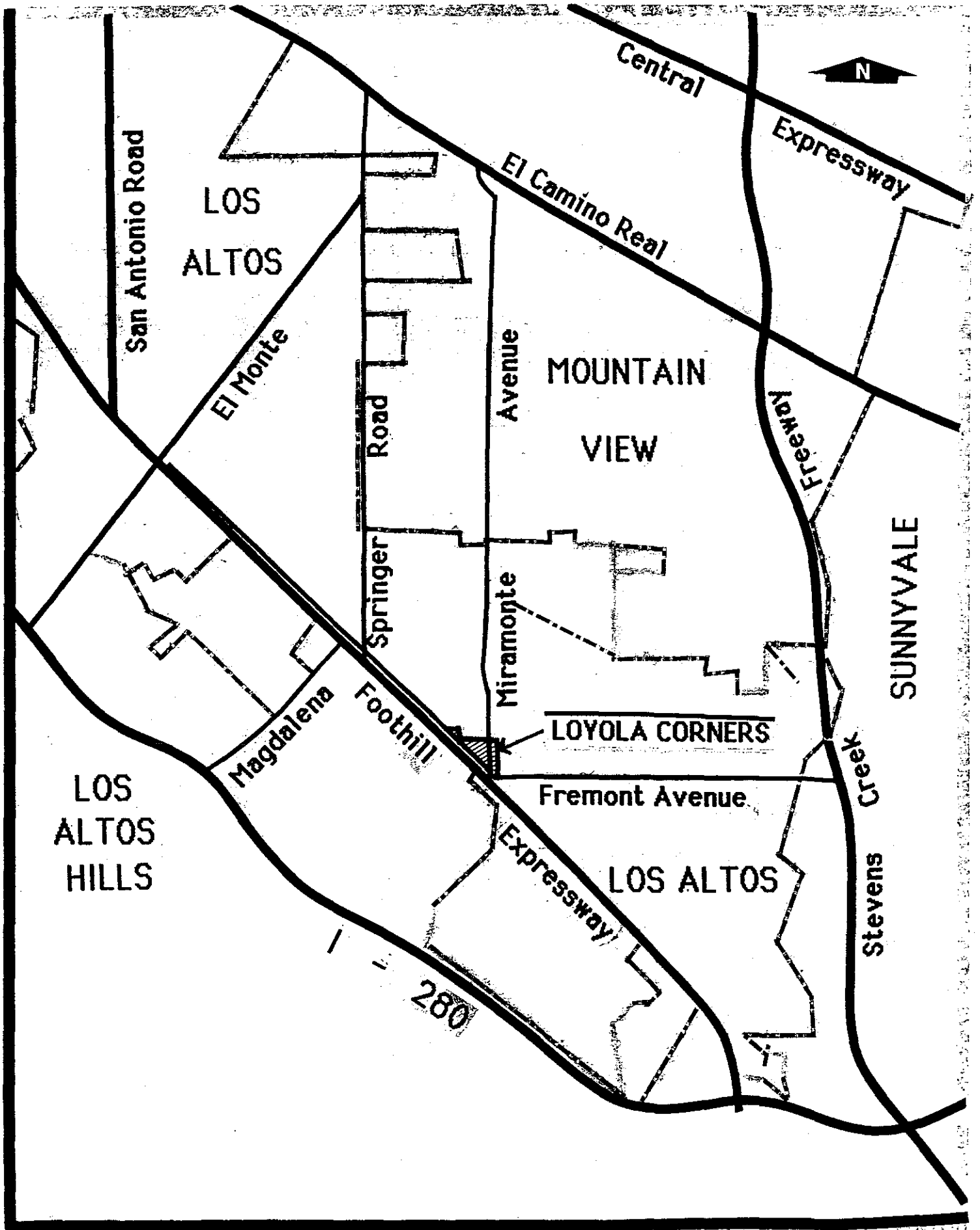

Location Map - Fig.1

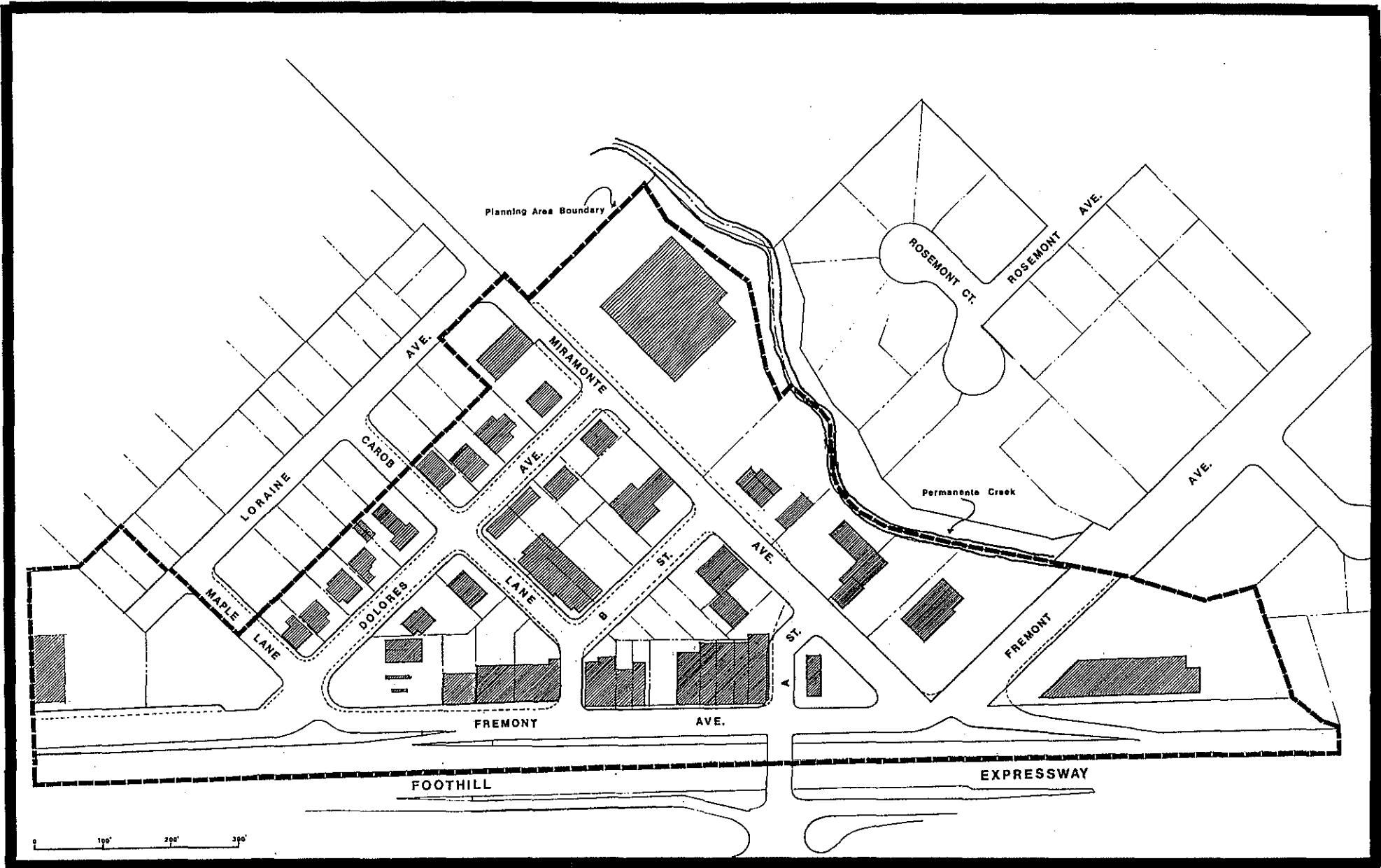

Planning Area

Fig. 2

Source: Donald A. Woolfe & Associates

2. Approximately 1.5 acres of residentially zoned land including 12 single family lots containing 11 single family residences. The residential property is served by Dolores Avenue, Loraine Avenue and Maple Lane, and
  
3. Approximately 6.5 acres of public street right-of-way.

Area topography (with the exception of the creek corridor) is flat to very gently sloping (0 - 4% gradient).

There are no vacant parcels as each property is fully developed with either buildings or paved off-street parking facilities.

The existing commercial buildings are essentially small one-story structures which (with the exception of 2 or 3 buildings) were constructed in the late 1940's to the early 1960's. Two or three buildings have second stories which are dedicated for office use. One recently completed mixed use project has commercial use on the first level and housing units above.

Visually, the area appears to be a mixture of unrelated structures, signs and street furniture with little or no landscaping extant. There is no established design focus. However, one unifying architectural feature occurs along Fremont Avenue where a covered arcade is formed by shingled roofs and structural posts (see Figure 6). The area behind the buildings fronting on Fremont and Miramonte Avenues is currently the major off-street parking facility for those buildings. This parking area is frequently characterized as a "sea of asphalt," with no landscaping, exposed trash receptacles - and inhospitable rear entrances to the commercial buildings. Similarly, there is little or no edge definition along the major streets and pedestrian walkways (as a result it gives the impression that everything just runs together).

The single family residential areas fronting on Dolores and Loraine Avenues are, in general, small (1,000-1,500 sq. ft.) single story, older homes. The serving streets are relatively narrow (20 ft. of pavement width) and do not have curbs, gutters and sidewalks.

The boundaries of the Planning Area do not include the residential property located along Lorraine Avenue. However, the Plan acknowledges potential impacts on those properties.

In summary, the commercial area may be described as an architecturally undistinguished visual blur which is compounded by the presence of obtrusive overhead utilities and a variety of antennae. (For additional descriptions of the area, see Community Design and Circulation and Parking sections of this Plan).

## II PURPOSE OF PLAN

This Specific Plan is prepared in accordance with the provisions of Section 65450 et. seq. of the California Government Code. The City of Los Altos General Plan contains a recommendation to prepare a Specific Plan for the area in order to address planning issues in a coordinated and comprehensive manner. This is the first Specific Plan required by the General Plan. Another fundamental purpose of the Specific Plan is to implement Goal 7 of the the Land Use Element of the City of Los Altos' General Plan. Goal 7 is to "Encourage and facilitate the long term viability of commercial activity at Loyola Corners."

The specific goals of this plan are to:

- 1) Create attractive and functional shopping and commercial use facilities in order to increase use and provide for long term viability.
- 2) Maintain the existing small, pedestrian scale of the area consistent with neighborhood commercial activity.
- 3) Recognize the need to preserve and protect adjacent residential neighborhoods from traffic, noise and visual impacts.
- 4) Provide a safe and effective circulation and parking system for motor vehicles, bicycles, and pedestrians, and
- 5) Provide for a mix of appropriate commercial uses which provide a range of desirable neighborhood-serving commercial uses.

**A. Assumptions** - This Plan was prepared under the following general assumptions:

- 1) Neighborhood/convenience commercial orientation to be retained, supplemented on a limited basis with retail service and office uses.

2) Retention of small scale development consistent with neighborhood commercial environment.

3) Minimal expansion of commercial uses.

4) In general, existing buildings are to remain with demolition and relocation held to an absolute minimum.

5) There is a general perception that significant traffic and circulation problems exist in terms of efficient traffic flow, traffic safety, parking and pedestrian access.

6) Adjacent residential neighborhoods will be protected to the maximum extent feasible from impacts created by commercial activity.

7) The Plan will be essentially implemented through private sector initiative with the City's role generally limited to:

a) Right -of-way abandonment and public improvements

b) Public Improvements to major parking areas and plazas.

c) Limited participation in property acquisition (only when said acquisition is deemed to be in the broader public interest).

d) Administration of the entity selected to implement the Specific Plan.

e) Review of proposed projects for Plan compliance.

**B. Use of the Plan** - This Specific Plan is intended to be used as follows:

1) By private land owners and buildings lessees :

- a) as a guide for future investment,
- b) to determine the types of acceptable and viable commercial uses, and
- c) to shape the magnitude and specific design for future improvements such as new buildings, building additions and site design improvements.

2) The City of Los Altos- The City staff, Planning Commission and City Council will use the Plan as a comparative "yardstick" :

- a) To evaluate specific proposals for development in terms of their consistency with the Specific Plan,
- b) To evaluate applications for building permits,
- c) To develop specific planning policies for the area,
- d) To use as a tool to assist in the adjudication of disagreements and to grant exceptions, and
- e) As a guide for public investment for public works projects and other public improvements. Indeed, Section 65455 of the California Government Code provides that actions by the City such as the construction of public works improvements or the adoption of subsequent zoning regulations within the area included in the plan must be consistent with the Plan.

3. Adjacent Residents - As a reference guide in order to determine the progress toward completion of those elements of the Plan which serve to preserve and protect neighboring residential areas from environmental impacts created within the commercial center.



In order to accomplish the above, the Plan contains descriptions of the key planning issues together with goals, policies and illustrative graphic plans. It should be carefully noted that the graphics contained in the Plan are purely illustrative. They do not constitute final design plans. Final plans for policy implementation will be prepared by the entity selected to implement the Specific Plan (see Implementation section). The purpose of the illustrative graphics is to provide an indication of the most desirable design and planning concepts and to indicate planning possibilities. In short, "a picture is worth a thousand words".

**C. Relationship to General Plan and Zoning Ordinance** - The City of Los Altos General Plan describes the planning area as neighborhood- serving commercial. The General Plan indicates that the City is undergoing a decline in retail activity and that this decline would adversely affect City residents. The Loyola Corners experience epitomizes this condition. Starting with the loss of the retail anchor (the Safeway supermarket) the area has undergone a noticeable decline in shopping activity. The General Plan states "a focus on retailing, therefore, is a critical element of the General Plan. It is important from a land use perspective. It is important to the City's fiscal vitality. It is important to maintaining the village character that so many residents value." To achieve this end the General Plan contains the followings goals:

**Goal 7:** Encourage and facilitate the long term viability of commercial activity at Loyola Corners.

**Goal 8:** Maintain and enhance the pleasant, attractive, neighborhood character of the Loyola Corners area.

**Goal 9:** Establish a circulation system to provide for convenient and safe travelways for motorized and non-motorized travel.  
(See appendix for additional policies and programs).

The commercial portion of the planning area is included within the CN (neighborhood commercial) zoning district. The specific purposes of this zoning classification are as follows:

- 1) To retain and enhance the neighborhood convenience character;
- 2) To preserve and improve the existing character by encouraging pedestrian-scale development and amenities, circulation, and landscaping;
- 3) To retain an emphasis on retail uses, including service and limited office uses;
- 4) To allow for mixed uses of commercial and residential; and
- 5) To buffer the impacts of commercial development on neighboring residential properties.

The CN zone permits, outright, a wide variety of retail and service uses, primarily to meet the needs of the surrounding residential districts. Administrative offices are also permitted; however, offices must be located on second floors only.

The following uses are permitted with the granting of a Conditional Use Permit:

- 1) Living quarters (on second floors)
- 2) Mixed use projects (retail, service, office and residential)

Also, a number of higher-impact commercial uses such as cocktail lounges, food markets and service stations are permitted under the granting of a Conditional Use Permit only if these uses are located further than 50 feet from an R1 (single family) District.

The key planning restrictions within the CN zone are:

- 1) No front or side yard setbacks required
- 2) 20 foot rear yard setback
- 3) Off-street parking - one space for each 200 sq. ft. of building.
- 4) 30 foot or two-story height limit.

This Specific Plan, when adopted by the City Council, is a component of the City's General Plan and is applicable only to the Loyola Corners planning area. No precedent for other areas of the City is intended or implied. The implementation actions and programs contained in this plan, as modified and adopted by the City Council, are not considered a part of the General Plan. Therefore, it is not necessary to amend the General Plan in order to modify, delete or supplement these actions.

This plan also contains recommendations for modifications of the City's Zoning Ordinance in order to implement adopted planning objectives. These changes must be reviewed and adopted at separate publicly noticed hearings in accordance with Sections 65853-65857 of the California Government Code. If an area of regulation is not addressed within the proposed changes it is intended that the existing applicable provisions of the Zoning Ordinance remain in force.

### **III THE PLANNING PROCESS**

In late 1985 the City retained a firm of planning consultants to study and identify alternative development concepts for Loyola Corners neighborhood commercial district. A series of public meetings was conducted in the first half of 1986 in order to obtain local citizen input regarding planning and development issues. A very generalized concept plan was subsequently submitted to the City in May, 1986. At this time a firm of traffic consultants was also retained to study existing circulation conditions and to identify selected issues.

As a result of these efforts, and the completion of the City's General Plan in 1988, the City Council appointed a 17 member Loyola Corners Study Advisory Committee. The Committee's charge was, essentially, to work with the City staff and consultants to identify: 1) planning issues, 2) alternative planning concepts, and to 3) recommend plans, policies and an implementation process to the City Council. The firm of Donald A. Woolfe & Associates was retained by the City as a first step in the preparation and implementation of a comprehensive planning strategy for the area.

As required by the City Council, an important goal of the process was to obtain maximum citizen involvement. To accomplish this objective a series of open public meetings, together with the distribution of two planning surveys was utilized. Many of the following proposed plan concepts and policies were derived directly from the information obtained through public participation. Also, as physical planning alternatives and concepts were developed, they were reviewed by local residents, commercial land owners and business operators as well as members of the Study Advisory Committee.

The technical process of plan preparation and review included the following tasks:

- 1) Site analysis and evaluation of existing improvements including community design survey,

- 2) Planning feasibility analysis, including preliminary identification of planning issues,
- 3) Preparation of alternative sketch diagrams,
- 4) Preparation of circulation and parking analysis,
- 5) Preparation of Market/Economic and Land Use study focusing on the identification of appropriate mix of commercial uses and magnitude of potential expansions.
- 6) Preparation of alternative sketch plans,
- 7) Identification of final specific planning issues and alternatives and ranking of acceptable planning solutions, and
- 8) Evaluation and selection of alternative plan implementation measures including financing.

In summary, a comprehensive and open process relying significantly on citizen participation was undertaken. The Study Advisory Committee worked in full partnership with the planning staff and consultants. A significant amount of time was spent in identifying and addressing key planning issues. As a result of these analyses, an extensive range of alternatives was evaluated against cost/benefit considerations which included social, environmental and neighborhood protection factors.

## **IV THE PLAN**

### **A. Basic Strategies and Priorities**

The two preeminent concerns articulated in the Plan are 1) the reestablishment of business momentum for Loyola Corners and 2) protecting nearby residents from unreasonable intrusions from the shopping area.

To carry out these priorities the Plan provides for:

1) Three Phases of Development (IA, IB and II) which will stimulate immediate, tangible actions to reestablish lost momentum and a series of longer term actions, phased over time. During the first three- five months, a quick-start clean-up campaign is recommended. The campaign will focus on 1) cleaning up and restriping the parking areas, particularly the area behind the buildings (central triangle) 2) moving and screening trash receptacles,, and 3) introducing landscaping in portable containers to immediately improve the appearance of the central triangle. This area, bounded by Miramonte, Fremont and Dolores Avenues is the heart of the shopping area and will be the focus of most of the actions. These public actions will be accompanied by a building painting program for the businesses jointly by the City and the businesses.

This immediate, high-impact work will be completed while the groundwork is being laid for the establishment of an entity to implement the longer range Plan for the creation of public plazas, street improvements, and those business expansions which are necessary in order to ensure the area's long term vitality (see Figures 3 and 4 and Implementation Section).

2) Steps to protect nearby residents. The protection of the homes on Dolores and Loraine Avenues and Maple Lane are integral components of the improvements to the shopping area. Initial or

LEGEND

- STUDY AREA BOUNDARY
- RESIDENTIAL BUILDINGS
- ▒ COMMERCIAL BUILDINGS
- REVISED TRAFFIC FLOW
- EXISTING TREES
- ⊙ PROPOSED TREES
- ⊛ FEATURE IN NEW PLAZA
- ★ TRASH ENCLOSURE

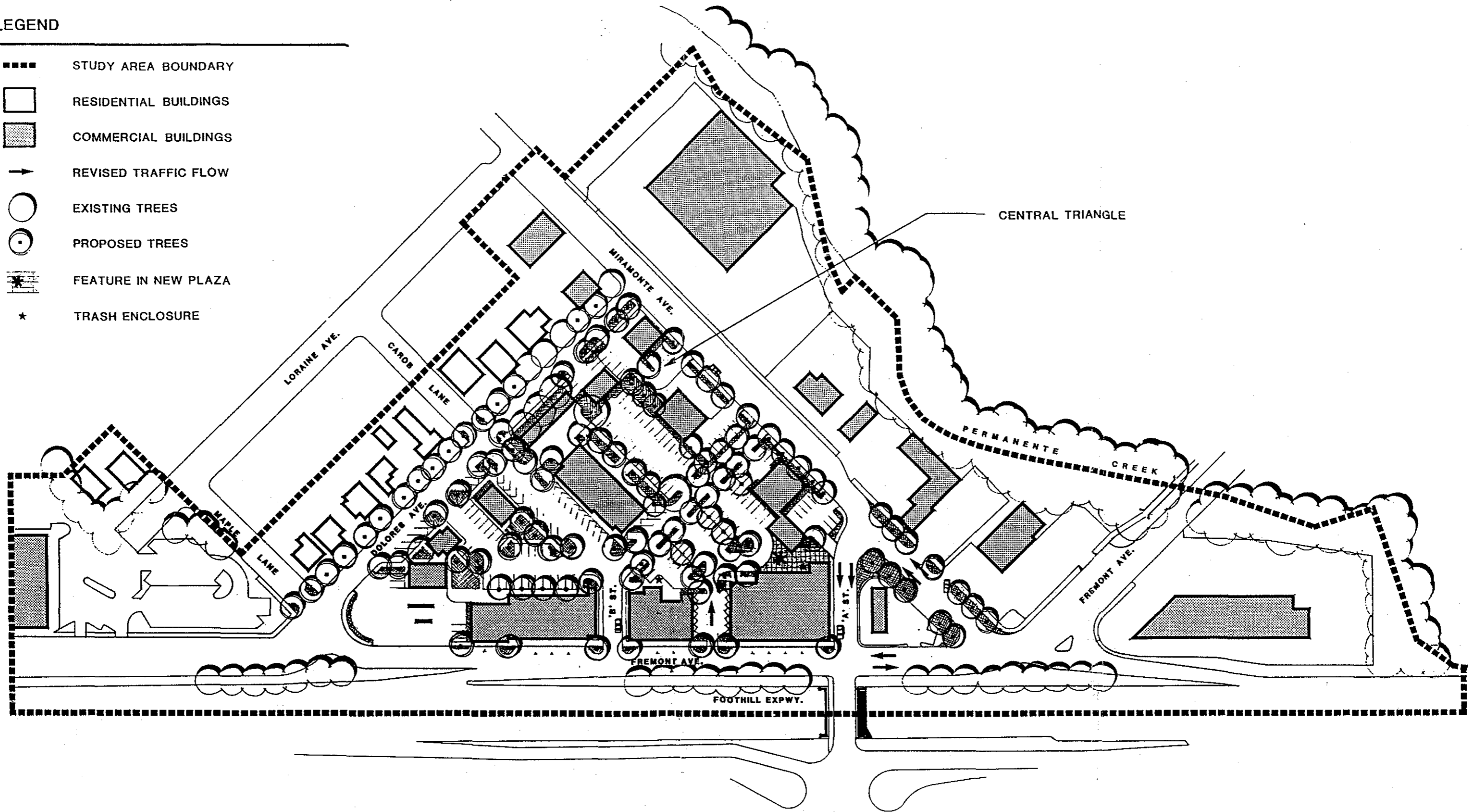
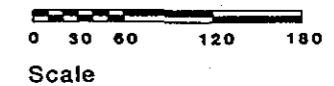

FIG. 3

ILLUSTRATIVE PLAN  
 PHASE I  
 LOYOLA CORNERS



Source: Donald A. Woolfe & Associates  
 Hardesty Associates, Landscape Architects

LEGEND

- STUDY AREA BOUNDARY
- RESIDENTIAL BUILDINGS
- COMMERCIAL BUILDINGS
- ▨ NEW CONSTRUCTION
- ▩ FEATURE IN NEW PLAZA
- REVISED TRAFFIC FLOW
- ||||| PEDESTRIAN CONNECTOR
- ..... CREEKSIDE WALK / BIKE TRAIL
- EXISTING TREES
- ⊙ PROPOSED TREES

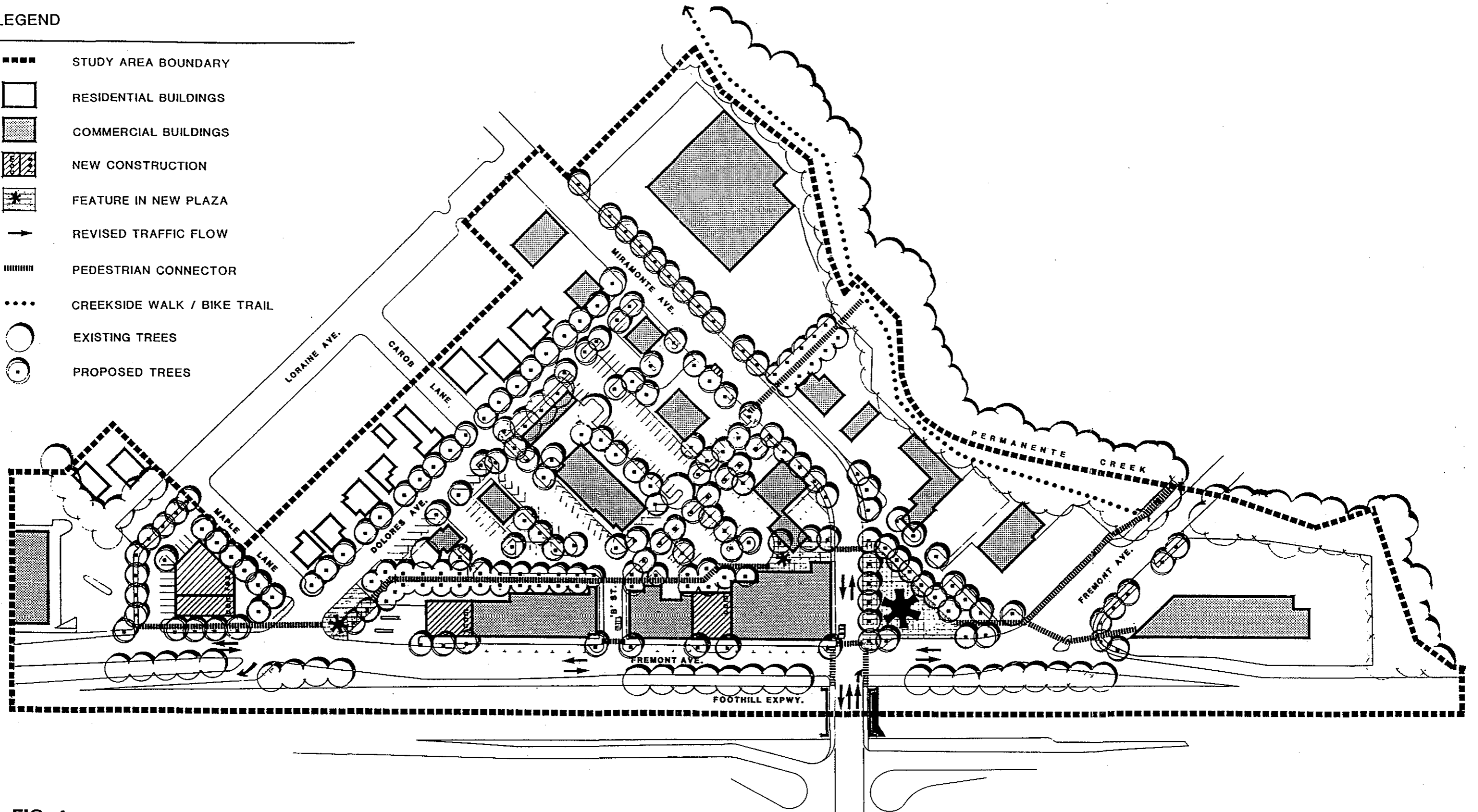
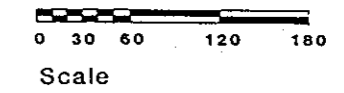

FIG. 4

ILLUSTRATIVE PLAN  
 PHASE II  
 LOYOLA CORNERS

Source: Donald A. Woolfe & Associates  
 Hardesty Associates, Landscape Architects





short-term steps will include 1) enhanced enforcement of parking regulations in order to inhibit employee parking on residential streets, 2) installation of signs prohibiting truck traffic on Loraine Ave. and 3) increased buffers to reduce the intrusion of traffic and noise into the residential area. Longer term actions will include 1) reducing through traffic on Dolores Ave. and Maple Lane , 2) requiring residential use on the rear portion of the undeveloped Bank of America parcel and 3) the fundamental policy declaration that existing residential properties fronting on Dolores and Loraine Aves and Maple Lane are all to remain in residential use.

A more detailed description of the Plan phases, together with Plan graphics, are presented below:

**A. Phase IA** - A 3 - 5 month immediate action program. It is designed to establish a new momentum through a series of immediate actions to remove negative visual perceptions and to bring a fresh appearance to the area. Highlights of the specific actions taken in Phase IA include:

- Painting of buildings
- Screening of trash receptacles
- Reorganizing and restriping parking in the future pedestrian and parking plaza
- Establishing a Business Improvement District to be formed by the Loyola Corners Business Association.
- Introduction of plant materials in moveable containers at high impact locations.
- Sign controls for employee parking and truck travel.
- Screen mechanical equipment and remove unnecessary antennae, ductwork, etc. on roofs.
- Initiate a sign control program and provide for unifying accessories such as coordinated awnings.
- Rezone the one residential property facing Miramonte Ave. at Dolores Ave. from residential to commercial use.

This initial program is not a substitute for more fundamental improvements, but rather is intended to demonstrate the commitment of the City and businesses while the necessary organizational work is being completed for longer term actions.

**B. Phase IB** - A one to three year program (see Figure 3)

This step focuses on establishing a Parking Assessment District or similar organization to undertake the major renovations to the Central Triangle area including the establishment of a pedestrian and parking plaza. The City will also complete traffic flow improvements at Miramonte and Fremont Avenues and the "A" St. traffic island. A new Zoning Ordinance, with controls and standards specifically tailored to Loyola Corners is recommended to guide renovations and expansion of up to 23,000 sq. ft. of commercial space. A new district (SPZ - Specific Plan Zone) will require use permits for additions and renovations as well as for new buildings, coupled with an expedited and streamlined process for approvals of projects which conform to this Plan. Use of conventional Planned Unit Development zoning for specific projects in the Loyola Corners area was considered but rejected because a separate customized zoning district will allow a coordinated set of regulations to ensure more consistent treatment of development in the entire area.

**Specific actions taken in Phase IB will include:**

- Establishing a Parking District or similar organizational structure to implement the Plan.
- Combine separate parcels into a single unit to create a unified pedestrian and parking plaza in the Central Triangle.
- Install permanent landscaping.
- Relocate and screen trash receptacles.
- Construct landscaped "bumpouts" along street frontages.
- Construct curbs, gutters and sidewalks to define circulation functions.
- Initiate a utility undergrounding program.

- Adopt a logo for the area and consider developing a "banner" identification program.
- Approve new zoning district for the area including specific protection for residences facing Dolores and Loraine Aves. and Maple Lane.
- Modify Fremont Avenue from one-way to two-way between Miramonte Ave. and "A" Street.
- Make Miramonte Ave. one-way from Fremont to "A" Street and "A" St. one-way from Miramonte Ave. to Fremont Ave.
- Continue landscape buffering along Dolores Avenue.
- Improve area lighting.

### **C. Phase II** (see Figure 4)

This series of steps will include longer term projects and actions that must await financing sources or other actions. These steps include realigning Miramonte Avenue in coordination with widening the bridge over Foothill Expressway, as well as relocating the north-bound on-ramp to Foothill Expressway so that Fremont Ave. can be made a two-way street. Two pedestrian plazas will be built, one at the site of a removed or relocated Photo Drive Up store and the other on a portion of the Beacon Gas Station site. The plaza will be linked by a pedestrian pathway behind the Fremont Ave. stores and along the edge of the pedestrian-parking plaza.

#### **Highlights of the specific actions taken in Phase II include:**

- Widen bridge across Foothill Expressway.
- Realign Miramonte Avenue to the present alignment of a widened "A" Street.

- Redesign the vacant Miramonte Ave. right-of-way to allow access to Echo Restaurant and Downey Saving and Loan.
- Construct a pedestrian theme plaza at the new "Loyola Corners" where Miramonte Ave. and Fremont Ave. meet. Remove or relocate the Photo Drive Up store to provide space for the plaza and visual theme structure.
- Construct a pedestrian pathway behind the Fremont Ave. stores at the edge of the pedestrian parking plaza from Miramonte Ave. near the intersection of Dolores Ave. and Maple Lane.
- Acquire an easement over the portion of the Beacon Gas Station next to Dolores Ave. Remove or relocate the Beacon Gas Station office building to a site adjacent to the present "Whitecliff" building. Use the additional space for a pedestrian theme plaza and to link up with the pedestrian walkway along the pedestrian-parking plaza.
- Relocate the north-bound on-ramp to the Foothill Expressway to the foot of Dolores Ave.
- Make Fremont Ave. a two-way street along its entire length in Loyola Corners.
- Allow construction of a combined retail/residential project on the present Bank of America surplus parking lot site. Install buffering for Loraine Ave. and Maple Lane neighbors.
- Install physical controls to limit truck access to Loraine Ave. if needed.

A detailed list of actions to be taken to carry out this Plan will be found in Table 2 in the Implementation Section.

## **B. Land Use**

Objectives - 1) Establish a balanced set of land uses which support an attractive and functional shopping area and 2) protect the nearby single family residential land uses and character.

Issues and Alternatives: The major land use concerns are to achieve the growth needed to sustain Loyola Corners as a strong shopping area while maintaining the neighborhood character of the center and the area. The commercial center is to remain within its present boundaries and, if it is to remain viable, seek more effective use of the existing commercial property. Ideally, adjacent residents are to be viewed as long term supportive neighbors. This will occur only if they are protected from unreasonable impacts and if they are provided with an attractive shopping experience.

Within the commercial center, the Plan calls for intensifying the retail uses which currently occupy approximately one-half of the total available space. Continuing the City's policy of requiring retail uses on first floors will assist in the gradual increase of retail stores. This increase is vital in order for Loyola Corners to compete more effectively with other centers. At the same time, small projects which provide for mixed retail and housing uses are encouraged where appropriate. These mixed uses provide convenient housing and add stability to the commercial area because these housing units represent a built-in market for the center.

In addition to the commercial and residential aspects, the plan provides for improved use and protection of the virtually ignored Permanente Creek. Also included is an analysis of alternative uses of the Post Office site.

## Policies and Standards

- LU -1 Retain existing land uses (with the exception of one single family residential site located on Miramonte Ave.).
- LU-2 Retain and protect adjacent residential uses from negative impacts.
- LU-3 Permit the existing residential use which fronts on Miramonte Ave. at Dolores Ave. to change from residential to retail use.
- LU-4 Continue and rigorously enforce existing City policy requiring retail uses on the first floor of commercial buildings.
- LU-5 Seek mixed use developments at appropriate locations in Loyola Corners, especially the Bank of America parking lot parcel. (see H - Policies for specific parcels).
- LU-6 Convert post office facility to full service postal facility or to retail use.
- LU-7 Create a linear park and pedestrian circulation corridor along Permanente Creek.

### **C. Protection of Adjacent Residential Neighborhoods**

Objective - Protect and enhance the residential neighborhood adjacent to Loyola Corners to assure long term continuation in residential use.

Issues and Alternatives - Concerns for adjacent residences include ensuring long term protection from conversion to commercial use, through traffic on Dolores Avenue, employee parking on all residential streets, truck traffic and parking on Loraine Avenue and the need for increased visual screening from commercial activities.

The potential of permanent closing of Dolores and Loraine Avenues was discussed but these ideas were rejected due to residents' concerns about loss of access to their property. The existing bus route along Dolores is a concern due to the narrowness of the street. This concern can be remedied when Fremont Ave. is made a two-way street again. The residents along Loraine Ave. were especially concerned over truck traffic.

Initially, signs will be used to control truck access and parking. More stringent controls such as the installation of control bollards which allow only one auto at a time onto the residential portion of the street will be used if needed. Increased visual buffering and screening is needed along all of Dolores Avenue, on Maple Lane and Loraine Avenue adjacent to the Bank of America parking lot property and to protect the residences on Dolores and Loraine Avenues when the residential parcel facing Miramonte Avenue at Dolores Avenue is converted to commercial use. Employee parking will be controlled initially by imposing a two hour parking limit on the residential streets.

#### **Policies and Standards**

- RP-1 Provide visual buffering from commercial activities (i.e. landscaping, street trees, walls as needed).



RP-2 Reduce through traffic by installing cul de sacs, bollards, etc. as required.

RP-3 Initiate and enforce two hour parking regulations on residential streets to discourage employee parking.

RP-4 All residential zoning to be retained with the single exception of the residential property facing Miramonte Ave. at Dolores Avenue.

RP-5 Remove bus routes from Dolores Ave. as soon as Fremont Avenue returns to two-way service (IR-11).

#### **D. Circulation**

Objective - Assure improved traffic flow to and within Loyola Corners and provide for greater safety for pedestrians and bicyclists and less disruption of nearby residential areas.

Issues and Alternatives - The existing circulation system at Loyola Corners is characterized by an awkward street layout which creates unnecessary traffic conflicts and congestion. While the individual intersections each work adequately, the combination of so many intersections located so close to one another results in an inefficient circulation system. The main concerns of the residents and merchants is to develop a more efficient system which would improve the access to the commercial area and optimize the safety of the system for pedestrians and bicyclists.

Several alternative street designs were evaluated (as described in the Technical Appendix) in order to determine the optimum circulation plan for Loyola Corners. The principles which guided the evaluation of alternatives were:

- 1) The number of traffic conflicts should be minimized and the efficiency of the street system should be maximized wherever possible.
- 2) The safety of local streets should be improved, especially for pedestrians and bicycles.
- 3) The street system should help locate and define the community including the street intersection which would be known as "Loyola Corners."

The Plan contains a prescription for the complete elimination of one existing intersection and the simplification of two others. The street system identified in the Plan would be able to serve the proposed expansion of the commercial center with less congestion and greater safety than is currently provided by the existing streets.

Loyola Corners is served by County Transit buses #23 (from Mountain View to San Jose) and #34 (from San Antonio Shopping Center to the Santa Clara CalTrain Station). Both routes follow Fremont Avenue. Because Fremont Avenue is currently one-way east-bound, the west-bound buses use Dolores Avenue. This street was not built to accommodate bus traffic. The County should be petitioned to return all transit services to Fremont Avenue as soon as it is made two-way through Loyola Corners.

## Policies and Standards

- CIR-1 Widen bridge over Foothill Expressway to 3 vehicular traffic lanes and improve the sidewalks on the bridge for pedestrians and bicycles (see Figure 4).
- CIR-2 As the initial step to establish simpler and safer traffic flow, redesign the intersections at Fremont and Miramonte Aves. and "A" Street. Make Fremont Avenue two-way from "A" Street to Miramonte Avenue, "A" St. one-way toward Fremont Avenue, and Miramonte Ave. one-way from Fremont Avenue (see Policy CIR-5 for long term policy for this intersection).
- CIR-3 Change Fremont Avenue to a two-way street from "A" Street to Dolores Avenue when the present north-bound on-ramp to Foothill Expressway is relocated to the intersection of Fremont and Dolores Avenues (see CIR-9).
- CIR-4 Retain parking and loading on Fremont Ave. without widening the right-of-way.
- CIR-5 Realign Miramonte Avenue to present location of "A" Street and widen "A" Street to provide for 3 lanes of traffic. Close the existing southerly portion of Miramonte Avenue right-of-way to improve circulation and safety and to provide space for pedestrian plaza and/or relocation of existing Photo Drive-Up store (see Figure 4).

CIR-6 Protect Loraine Ave. from through and truck traffic

CIR-7 Change the existing two-way traffic flow on Dolores Avenue to one-way from Miramonte Ave. to Fremont Avenue once Fremont Avenue is made a two-way street (CIR-3).

CIR-8 Prohibit commercial truck and employee parking on residential streets.

CIR-9 Relocate the Foothill Expressway northbound on-ramp to the intersection at Dolores and Fremont Avenues (see Figure 4).

CIR-10 Provide adequate and safe pedestrian and bike paths to and through Loyola Corners.

CIR-11 Remove bus routes from Dolores Avenue to Fremont Avenue as soon as Fremont Avenue is restored to two-way traffic.

## **E. Parking**

Objective - Assure adequate parking to support Loyola Corners at locations which make shopping easier and which do not disrupt nearby residential areas.

Issues and Alternatives - At present there are insufficient parking spaces in the Loyola Corners area to meet the requirements of the current City zoning

regulations. Based on the current off-street standard of one space per each 200 sq. ft. of retail or office space, the zoning code requires 552 spaces and currently only 492 are available. Of course full utilization of parking facilities occur only within peak periods. This means that even a moderate increase in business in the Central Triangle might be restrained by a lack of peak period parking. Further, no commercial building expansion is now allowed on many sites because parking on the individual sites is inadequate. Preliminary design analysis indicates that approximately 70 additional parking spaces could be gained in the Central Triangle area by merging individual properties and redesigning the layout. A Parking District or similar organizational structure having condemnation or land assembly abilities would be required to accomplish this. Even so, new commercial buildings or most additions to existing buildings would be prohibited due to the lack of space to add additional parking spaces. Review of the current parking standards suggests that a somewhat more liberal standard of one space for each 250 sq. ft. would be appropriate for this area. Therefore, the Plan calls for changing the parking standards to allow up to an additional 23,000 sq. ft. of needed commercial expansion.

Loading spaces and truck access must also be incorporated into the final plan design so that stores fronting on Fremont Avenue may be served once the new parking-pedestrian plaza is built. It is possible, however, that some stores may have to be served from along Fremont Avenue. In order to eliminate potential two-way through traffic and truck delivery conflicts it would be necessary to widen Fremont Avenue. This could only be accomplished by constructing a high retaining wall adjacent to the express-way. The traffic and parking conflicts caused by these deliveries will have to be accepted because the cost of building a larger retaining wall and widening the right-of-way is viewed as prohibitive.

In addition, the parcel containing the existing vacant beauty shop on Dolores Avenue should be acquired to provide improved access and additional parking in the proposed pedestrian-parking plaza within the Central Triangle.

## Policies and Standards

- P-1 Redesign area behind the existing stores fronting on Fremont Avenue and Miramonte Avenue to create an aesthetically pleasing and functional landscaped pedestrian and parking plaza.
  
- P-2 Design parking layout to ensure adequate truck deliveries for all stores.
  
- P-3 Establish a Parking Assessment District or similar organizational structure to acquire properties and to design and construct the parking area and to carry out other steps needed to implement the Plan.
  
- P-4 Provide additional commercial building space by revising current parking standards from one space per 200 sq. ft. of commercial building area to one space per 250 sq. ft.
  
- P-5 Regulate employee parking so that it does not impact residential streets.
  
- P-6 If Fremont Ave. becomes a two-way street, provide for parking and truck unloading within the space provided by the existing right-of-way.

P-7 Remove existing vacant beauty shop facing Dolores Avenue to provide for improved access and additional parking for the pedestrian-parking plaza.

## **F. Economic Viability**

Objective - Ensure economic viability of Loyola Corners without creating unacceptable negative impacts on nearby residential areas.

Issues and Alternatives - Loyola Corners is in the midst of a concentrated relatively affluent trade area (see Fig. 5) It is also surrounded on three sides by four competing commercial centers. Most of those centers are larger and under single ownership which ensures coordinated selection of retail uses, hours of operation, promotions and design control. In order to compete effectively, Loyola Corners must expand in order to achieve a more coherent and harmonious mix of stores. This proposed mix should prove beneficial since it will help reinforce each business and provide for more effective marketing and promotion.

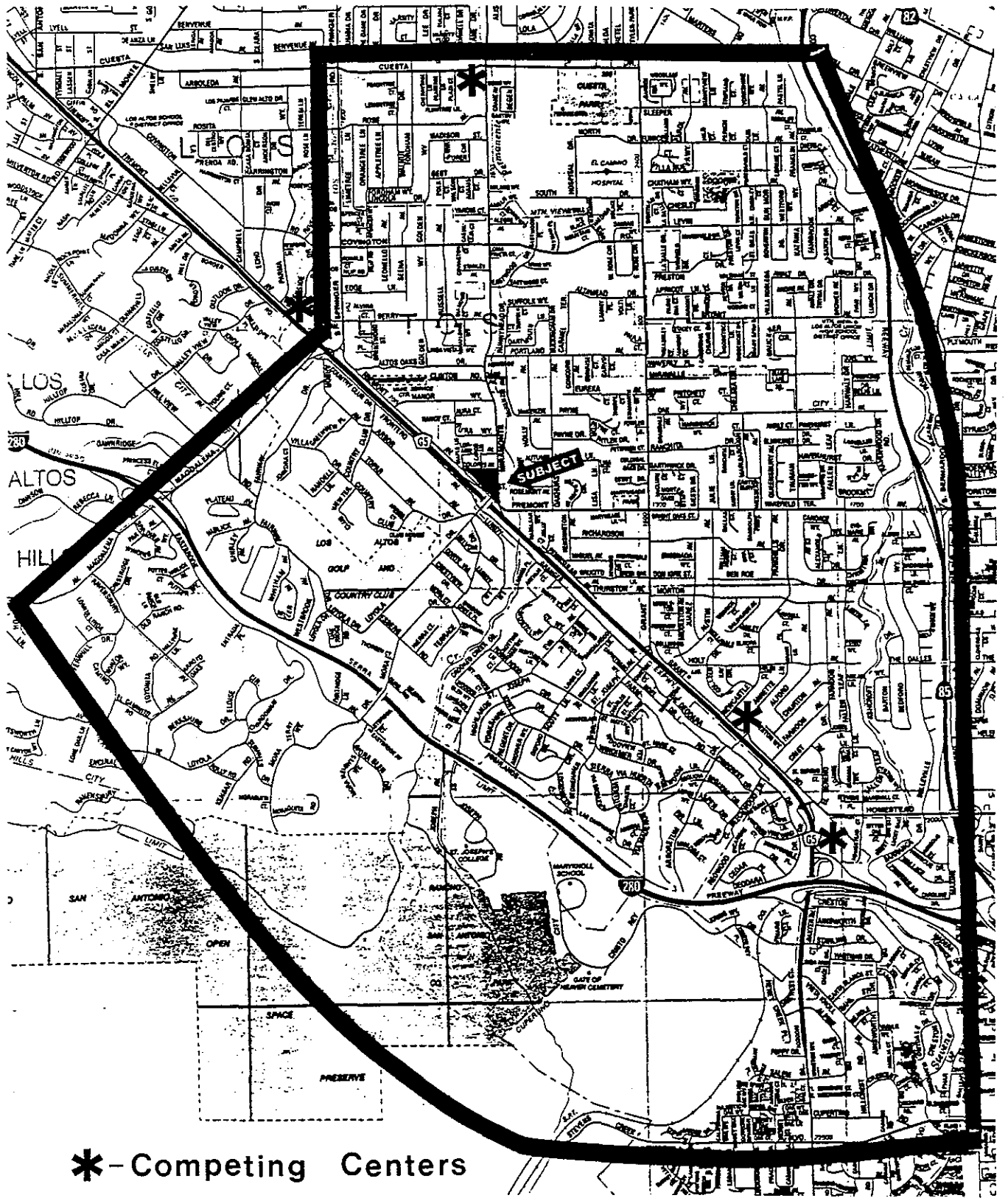

**Trade Area Map**

**Fig.5**



These conclusions result from the Economic Analysis for Loyola Corners (see Appendix B). The analysis is based upon:

1. Reviewing the results of residents' meetings and surveys conducted earlier by the Study Advisory Committee which identified residents' concerns and interest in types of stores and services.
2. Interviews with business leaders in Loyola Corners and with the Loyola Corners Business Association to gain insights on special concerns of businesses and their view of opportunities.
3. Field inspections of Loyola Corners, the five closest competing neighborhood centers, and Downtown Los Altos to identify numbers and types of stores in the immediate market area, access routes and other features affecting business at Loyola Corners.
4. Commercial Market Report identifying the numbers, buying power, and unique lifestyles and purchasing preferences of persons in the market area. The Commercial Market Report identified the types of stores for which there is the strongest unmet demand in this area.
5. Analysis of City data and data from other sources to gain insights into trends and prospects. The data used included square footages and sales tax revenues for Los Altos and neighborhood shopping areas.
6. Review and analysis of all the findings to prepare recommendations which incorporate results from the Commercial Market Report, interviews and other data to pinpoint the types of stores which have the strongest market potential and are appropriate for Loyola Corners.

A summary of the conclusions for economic growth of the center indicate that the two best growth opportunities for Loyola Corners are connected to building on existing successes in two areas; specialty foods and the bike, pool and patio stores. Specifically:

1. Loyola Corners now has a well established, family owned meat and seafood store, an ice cream shop next door, and a growing reputation for its new Farmer's Market on Saturdays. These existing attractions could be augmented with other small scale food related stores such as a bakery, a health food or a dairy store. Moving the Farmer's Market into the middle of the Loyola Corners center will be important to the success of this strategy.
2. The bicycle shop and the pool and patio store attract customers from a large trade area. The bike store especially brings in large numbers of people who could also be interested in purchasing related informal, family clothing or other types of sports equipment such as children's bicycles. Bike shop and pool store customers could also be attracted to food related shops such as a bakery, health food, produce or dairy store.

Most of the other stores in Loyola Corners provide a reasonable mix of services to the trade area.

In summary, the stores with the best potential for growth include:

Bakery

Produce store or year-round farmers' market

Health foods

Dairy products

Outdoor/informal apparel

Sports equipment compatible with bike sales such as children's bikes.

Other stores and services which appear to have market potential include:

Copy center/office supplies

Electrical and furniture repair services

Post office services - postal facility or within another store

The choice of retail stores, as well as the amount of expansion, needs to reflect the existing building size and configuration, availability of parking and the neighborhood setting. The existing buildings and stores are relatively small. New stores or additions should be in harmony with that small neighborhood scale. First priority for expansion should be given to existing stores, followed by selected new stores. The new stores should complement the key existing stores - the bicycle shop, pool and patio store, the meat and seafood market and the Farmer's Market. The Farmer's Market should move to the Pedestrian/Parking Plaza of the Central Triangle to bring additional benefit to the other stores. These actions will help define the image of Loyola Corners, induce existing customers to make multiple purchases on each visit, and attract more patrons from the trade area as well as help retain the neighborhood character of the center.

#### Policies and Standards

EV -1 Allow selected additional retail businesses and improve mix of stores to ensure economic vitality and ability to compete with other centers.

EV -2 Provide for additional building space in order to enhance the center's competitive position.

EV -3 Base expansion on a strategy which builds on existing strengths and adds new business which may be appropriate in terms of specific use, physical scale and size of site.

EV -4 Give priority to the expansion of existing businesses. Other expansion should be primarily for retail stores which complement or enhance the Loyola Corners business mix.

EV -5 Give first consideration for retail expansion to food stores (dairy, health foods, produce and specialty bakery), apparel stores (women's and children, family and sports), auto supply and copy shop.

EV -6 Relocate the Farmer's Market to the central Pedestrian/Parking Plaza behind the Fremont Ave. stores in order to benefit the other stores in Loyola Corners.

## **G. Expansion**

**Objective:** Allow moderate expansion needed for economic viability of the stores but establish a maximum total size and scale that will not substantially change the character of the center and the neighborhood.

**Issues and Alternatives:** Loyola Corners needs to expand to remain competitive but it also needs to retain its neighborhood character. The magnitude of expansion is limited by the availability of off-street parking and availability of land. Modifying the parking standards (see Parking Policy P-4) will allow up to 23,000 additional sq. ft. This would represent an increase of approximately 25% in the absolute building size of Loyola Corners, and is considered a

reasonable limit on expansion. Further, an analysis of potential traffic generation indicates that the 25% expansion would not result in serious negative circulation impacts.

Four alternative expansion concepts were considered as follows:

- 1) In new single story buildings
- 2) In new single story additions to existing buildings
- 3) In new two-story buildings, and
- 4) In second story additions to existing buildings.

The total number of parking spaces projected in the Plan is limited to approximately 560. Some of those spaces could be lost if new buildings are constructed. Accordingly, second story additions to existing buildings will be encouraged along with a limited number of new buildings providing retail space on the first floor and offices or housing above.

In allocating space for expansion, the following definitions should be used:

Retail stores are commercial establishments which predominantly sell products rather than services, directly to the general public, generally for household use, on a daily basis. Examples include groceries, produce markets, liquor stores, furniture stores, sporting goods and gas stations. These type of establishments tend to draw other people into the area. With the exception of produce markets and other grocery stores, these businesses also produce significant levels of sales tax revenue for the City.

Retail Services are commercial establishments which predominantly sell services directly to the general public, generally for household use, on a daily basis. Examples include beauty and barber shops, banks, dry cleaners and repair shops. These types of establishments do not generate significant levels of sales tax revenues for the City.

Offices are commercial establishments which predominantly sell services to the general public or to businesses and other customers as well. The contact with the general public is not as frequent as with retail services and a significant portion of the business may take place at other locations. Examples include law offices, accountants, medical, advertising and software computer programming. Of course, office uses do not generate sales tax revenues.

Since Loyola Corners is essentially a neighborhood business center, it is anticipated that the focus of the marketing efforts and product/service mix of any new establishments will be predominantly oriented to serve nearby residents.

The projected 23,000 sq. ft. of expansion of commercial spaces cited above is to be aggregated as follows:

New ground level retail	-	15,000	sq. ft.
Second level retail services	-	4,000	sq. ft.
Second level office use	-	<u>4,000</u>	<u>sq. ft.</u>
Total		23,000	sq. ft.

This expansion is based upon (in addition to off-street parking requirements) a desired goal of obtaining an approximate ratio of 70% retail space to 30% office uses. This allocation is considered desirable because:

1. Loyola Corners is, in terms of logical land use planning, a neighborhood retail center whose function it is to provide retail services to the surrounding community. Correspondingly, this area is not well suited to domination by administrative office uses which require a different set of support facilities and services together with a different trade area.

2. A commercial area dominated by office uses usually does not provide for a lively, active and diversified shopping experience (it is interesting to note that shopping centers do not, as a rule, contain office uses).
3. Cost-benefit implications. The 70% / 30% ratio is intended to ensure that a reasonable portion of the commercial activities are generating taxable retail sales. This is necessary in order to at least partially defray the costs of city services to the area.

The relationship of existing uses to proposed commercial expansion is indicated in Table 1 below:

**TABLE 1**

**Commercial Land Uses in Loyola Corners  
Existing and Recommended**

Building Usage (Thousands of Square Feet)

Commercial Activity	Existing 990		Fill <sup>1</sup> Vacancies		Demolitions <sup>2</sup>		Expansion		Maximum Development <sup>3</sup>	
Retail	44.0	48%	+6.0	54%	-1.0	50%	15.0	65%	64.0	57%
Retail Services	8.0	9%	-		-1.0	50%	4.0	17%	11.0	10%
Offices	28.0	31%	+5.0	46%	-	-	4.0	17%	37.0	33%
Vacancies	11.0	12%								
<b>Total</b>	<b>91.0</b>	<b>12%</b>	<b>n.c</b>	<b>100%</b>	<b>-2.0</b>	<b>100%</b>	<b>23.0</b>	<b>100%</b>	<b>112.0</b>	<b>100%</b>

<sup>1</sup> Loyola Corners all retail; Whitecliff mixed use; Alcheck buildings all offices(See SP.4 for more details).

<sup>2</sup>Photo drive-up building and vacant beauty shop on Delores St.

<sup>3</sup> Maximum development. A vacancy rate of 5% is more likely.



In addition to the expansion of commercial space, it is desirable to permit mixed uses incorporating residential units on second building floors. This is considered advantageous since on-site residential units provide an expanded nearby trade area and reduces motor vehicle trips. Currently there is one mixed use project in the planning area consisting of 6,000 sq. ft. of first floor retail space and five residential condominium units above. It is recommended that a maximum of 20 additional, second level units be permitted, provided that at least one off-street parking place is provided on site for each residential unit. Additional residential parking needs may be considered partially fulfilled through the use of shared parking (with the adjoining commercial parking).

The plan also establishes the policy of requiring the minimization of impacts on existing businesses by the construction of new buildings and additions. This may best be accomplished (in addition to required design review) by requiring that parking, landscaping and other amenities lost due to new construction be replaced in kind and/or in-lieu.

### Policies and Standards

- EX -1 Change current zoning parking requirements so that expansion in the Loyola Corners area can be permitted (see Parking Policy P-1).
- EX -2 Establish a Parking Assessment District or similar organizational structure to implement the Specific Plan. The District shall have authority to assemble property and design, construct and manage the area (see Parking Policy P-3).
- EX -3 Allow a maximum expansion of commercial floor area of 23,000 sq. ft. (approximately 15,000 sq. ft. for retail, 4,000 sq. ft. for offices and 4,000 sq. ft. of retail services).

EX -4 Allow expansion to be of two types, new buildings or additions to existing structures. New buildings may be created on existing available property or by removing existing structures and rebuilding. Expansion of existing buildings may be either horizontal (single story additions) or vertical (second stories.)

EX -5 All expansion must retain or replace any required parking spaces, landscaping or other amenities.

EX -6 Anticipate that most expansion will be intended for retail stores only. It is expected that expansion will be on the order of 15,000 sq. ft. unless some establishments need to add a second story for internal office and storage functions. If this occurs, total expansion could reach approximately 23,000 sq. ft.

#### **H. Policies for Specific Parcels**

The following policies are intended to guide land use decisions for three key parcels in the Loyola Corners area:

## **SP-1 Bank of America Parking Lot**

Location: Adjacent to Bank of America facility

Assessors Parcel : 189-15-91

The front portion of this parcel facing Fremont Avenue should be used for up to 2,000 sq. ft. of retail or retail service use in a single story structure. All such retail or service uses shall face Fremont Avenue. The rear portion of the parcel facing Maple Lane and Loraine Avenue should be used for up to three townhouses or condominium dwellings oriented toward Loraine Avenue or Maple Lane.

Design of the site should make provision for:

1. Eventual relocation of the north-bound on ramp to Foothill Expressway to the foot of Dolores Avenue (see Plan, Phase II)
2. Eventual opening up of a pedestrian way past the gas station (see SP-2 below) to visually link this area and the Bank of America parcel with the Central Triangle plaza area of Loyola Corners.
3. Maximum visual screening from single family residential properties.
4. Offstreet parking: 8 spaces for commercial and 6-8 spaces for residential uses.

## **SP-2 Beacon Gas Station Site**

Location: Intersection of Dolores and Fremont Avenues.

Assessors Parcel Number: 189-15-73

The rear portion of this parcel adjacent to Dolores Avenue should eventually be rebuilt as a pedestrian plaza in order to visually link the Bank of America property with the Central Triangle Plaza. The small pedestrian plaza indicated in the plan at the corner of Dolores and Fremont Avenues will also serve as a destination node connecting through the Pedestrian/Parking Plaza with the larger main plaza located at the intersection of Miramonte Ave. and "A" St.

It is anticipated that these improvements could be carried out without requiring closure of the existing gas station on the site. It is recommended that the existing gas station office be moved or rebuilt along the southern portion of the site adjacent to the existing Whitecliff Realty building. This change could provide space for the public plaza, pedestrian way and visual link to the interior of the parking plaza. Entry and exit to the station from Dolores Avenue could be achieved without unduly restricting operation of the gas station. This approach was viewed as preferable to total removal of the gas station, since the station currently performs a useful neighborhood function.

Some of the land needed for the small pedestrian plaza at the intersection of Fremont and Dolores Avenues would be available due to the redesign of the existing underutilized sidewalk and landscaping at the corner.

### **SP - 3 Photo Drive-Up Site**

Location: Intersection of Miramonte Avenue, "A" St. and Fremont Ave.  
Assessors Parcel Number: 189-15-92

This parcel should be combined with additional land made available by the realignment of Miramonte Avenue which incorporates "A" St. (see Circulation Section). This will provide sufficient area needed for the larger public pedestrian plaza shown in the plan. The purpose of the plaza is to improve traffic safety and to create a highly visible public space along Fremont Avenue at the north-bound off ramp from Foothill Expressway. Also, this will allow a view into the center of Loyola Corners from the Expressway. In addition, the plaza is intended to link the Central Triangle Pedestrian and Parking Plaza with this site and the commercial buildings along Fremont Avenue at the southern end of Loyola Corners.

The existing Photo Drive-Up building, currently occupying a portion of this site, should be removed. This is considered one of the highest priorities of the specific plans. If this is not financially feasible, the business could be relocated to another part of the center or the building moved from its current location (facing "A" St.) to a location on the site oriented on the same longitudinal axis as Miramonte Ave. However, removing the structure is the preferable option.

### **SP - 4 Whitecliff Building, 935 Fremont**

Location: Adjacent to Beacon Gas Station site fronting on Fremont Avenue.

Assessors Parcel Number: 189-15-80

This building has been remodeled several times and has, most recently, been used as a real estate sales office. The building is located at the westerly terminus of the existing covered arcade. The front of the building projects to the edge of the arcade roof eave. This

condition results in a physical termination to the arcade walkway which is considered to be a desirable unifying architectural element (see Figs. 4 & 12). Therefore, it is recommended that this building be modified to allow the continuation of the arcade.

The first floor of the building, at present, is not physically suited for retail uses. Also, it has been vacant for more than one year. It would be appropriate to allow a limited, interim use of the building for offices located on the first floor. Such interim use should be for a period not to exceed three years. At that time the use shall be reviewed. Also, any future exterior alterations should be consistent with the design standards adopted for the area.

### **I. Utilities**

Utilities for the planning area are provided as follows:

Sewer - City of Los Altos  
Storm Drainage - City of Los Altos  
Water - California Water Service  
Electricity - Pacific Gas and Electric  
Gas - Pacific Gas and Electric  
Telephone - Pacific Bell  
Cable Television - United Cable

All of the above utilities are considered to be adequate to serve existing needs and accommodate anticipated near term expansion.

Utilities, in general, are located in public rights of way as follows:

<u>Street</u>	<u>Service Lines</u>
Miramonte Avenue	•6" sewer, 4", 8", 24" water, 3" gas electricity, telephone & cable T.V.
Fremont Avenue	•4" gas, electricity, telephone and cable T.V.
Dolores Avenue	•6" sewer, 8" water, 2" gas, 12" storm drain, electricity, telephone and cable T.V.
"B" Street	•6" sewer, 1 1/2" water, 2" gas
"A" Street	•4" water, 8" water
Carob Lane (south of Dolores Ave. )	•6" sewer, 2 1/2 " water, 3/4" gas
" " (north of Dolores Ave.)	•2 1/2" water
Maple Lane	•6" sewer, 2 1/2" gas

## **J. Community Design and Beautification**

Objectives: 1) Create a harmonious and coordinated visual identity for the area which attracts people to Loyola Corners and enhances the nearby residential environment.

2) Provide a convenient, safe and attractive environment which complements the character of the adjacent residential area and of the entire City.

Issues and Alternatives : Community design or aesthetics refers to the visual appearance and functional relationships of the various physical components and the total physical setting of the planning area. As with all aesthetic issues inherent in community design, recognition of how residents feel about the area in terms of the relationship between people and the constructed environment is paramount.

A partial description of the existing "designed" environment, together with the resulting feelings evoked is found in Section I, Area Description. In summary, the commercial triangle bounded by Miramonte and Fremont Avenues tends to be perceived as a deteriorating, highly fragmented mixture of proximate uses formed by remnants of older residential and commercial structures. There is no coherent design plan for the area. In general, the characteristics which create these perceptions are:

1. Lack of distinguishable form or identity
2. Chaotic visual character (signs, materials, colors, overhead utilities, etc. - see Figure 6).
3. Lack of clear definition of functions (i.e. edges of streets, walkways, waste collection, entrances and exits, street furniture, etc.)
4. Age and inconsistent maintenance of certain structures.
5. Lack of landscaping and open space areas.



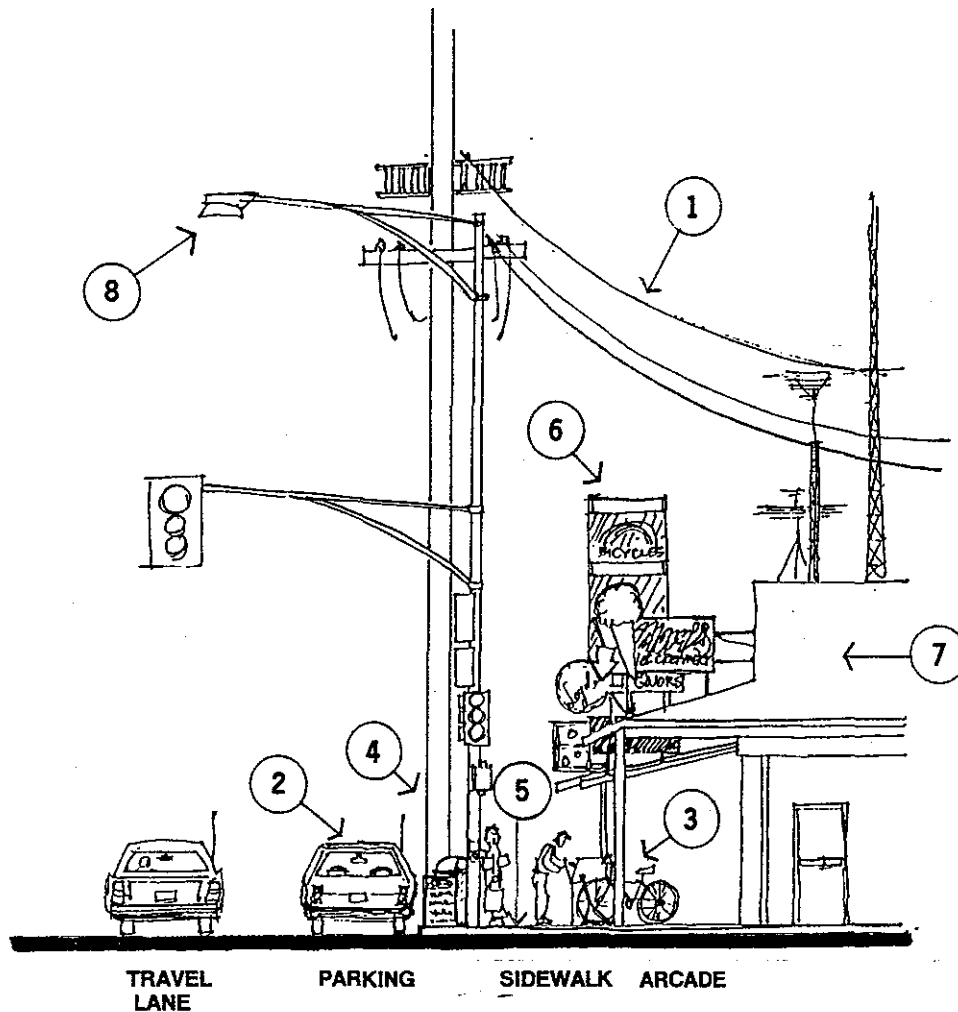
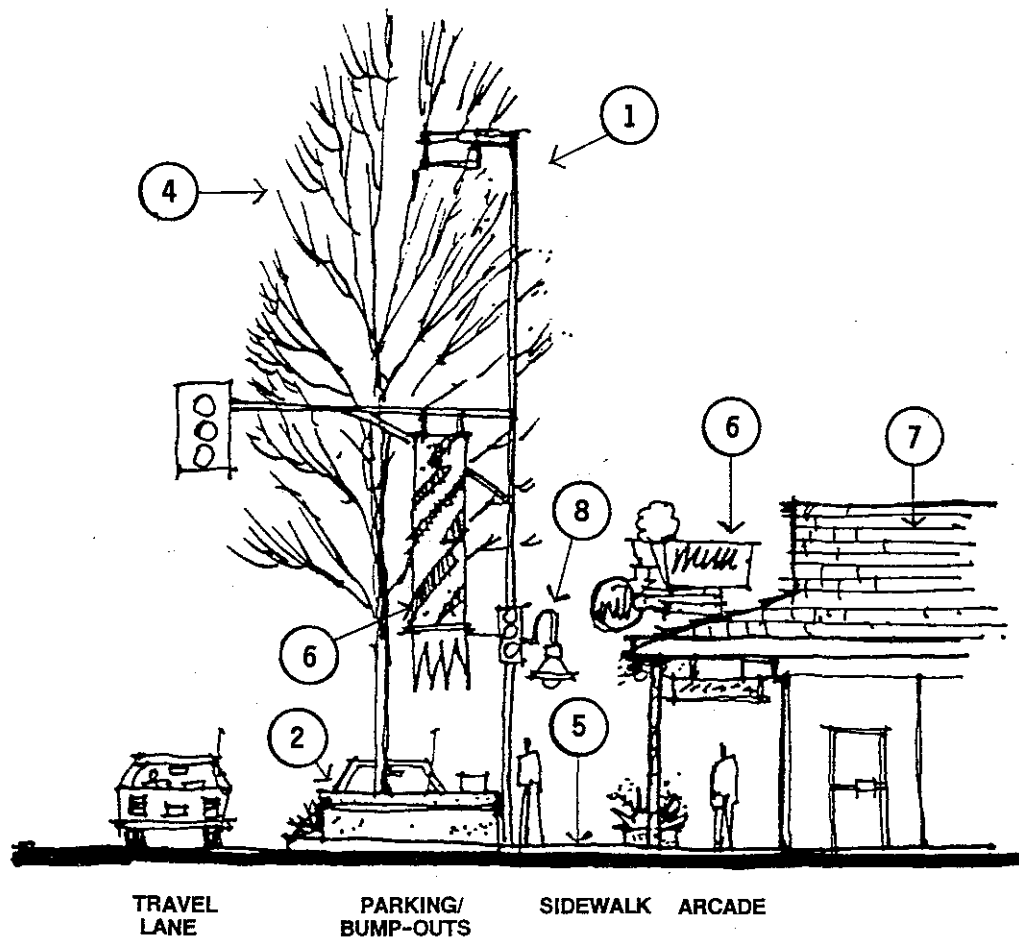

**FIG. 6 EXISTING VIEW AT FREMONT & 'A' ST.**

**PROBLEMS**

- |  |   |
|--|---|
| <p>1. Overhead utility wires, poles, antennas on roofs create visual chaos.</p> <p>2. Traffic lanes and parked cars hard against pedestrian walks at building fronts.</p> <p>3. Congestion of sidewalks by haphazard location of newspaper racks, bike racks, trash containers.</p> <p>4. Lack of plantings, trees and seating create uninviting appearance to storefronts/back.</p> | <p>5. Paving uneven, patched, has "worn" look.</p> <p>6. Signage competition makes visual clutter. Store window displays done with little apparent forethought, adding to confusion.</p> <p>7. Colors and building materials vary greatly and create "piecemeal" look.</p> <p>8. Nighttime lighting poor under canopies, harsh at sidewalk areas.</p> |
|--|---|

Source: Donald A. Woolfe & Associates  
 Hardesty Associates, Landscape Architects



**FIG. 7 PROPOSED VIEW AT FREMONT & 'A' ST.**

**SOLUTIONS**

- |   |  |
|---|--|
| <p>1. Relocate utilities underground, remove antennas and other nonessential wires from roofing.</p> <p>2. Create friendly pedestrian "bump-outs" with room for trees and planting, to create more inviting streetscape.</p> <p>3. Use space created by "bump-outs" to provide seating, bike parking, news racks, etc. and keep walkways clear.</p> <p>4. Institute tree planting program at streets and parking areas. Use shrubs and vines to screen unsightly areas.</p> <p>5. Use warm colored pavers to highlight entries, crosswalks and pedestrian nodes. Pavers will also provide visual and physical link to all shopping areas. Replace concrete sidewalks as needed.</p> | <p>6. Develop unified signage program with similar style, type and material for all businesses. Limit size, mounting heights etc. to address the pedestrian. Limit window signs, sale signs etc. where redundant to avoid cluttered look. Give thought to window composition to harmonize with adjacent shops. Provide banners at major intersections and parking areas to identify "Loyola Corners" as a major shopping district.</p> <p>7. Develop materials and color schedule to repaint buildings, reroof, and screen trash areas. Add trees and flowers in free standing planters to add color and interest. This will go a long way to "make over" the image of the area without major architectural changes and large dollar investment.</p> <p>8. Add pedestrian scale lighting to create more inviting atmosphere at night and boost safety and security in entire area.</p> |
|---|--|
- Source: Donald A. Woolfe & Associates  
Hardesty Associates, Landscape Architects

That portion of the area lying east of Miramonte Avenue contains larger and less visually interdependent structures. This area is usually perceived as containing better designed, auto-oriented, drive-up uses. One site deserves special note; the current post office site (the former Safeway property between Miramonte Avenue and the Creek ) is perceived as being visually intrusive and out of scale with the remainder of the neighborhood oriented center. The building location, materials, color, building mass and scale, together with the unrelieved large parking area (containing highly visible trucks) combine to create negative feelings.

The area along the Permanente Creek corridor affords a rare opportunity to provide needed open space experiences along the easterly margin of the planning area. The existence of the creek also provides an opportunity for the planning of adjacent uses to incorporate the stream corridor into future site plans and building modifications.

The key issue involving aesthetics for Loyola Corners is that if the area is to remain commercially competitive vis a vis other centers, it must achieve a more coherent and functional plan and improve visual quality. This, to a large degree, may be accomplished by implementing the Specific Plan and also through the adoption of design policies, specific standards and a rigorous design review process (also, see Figures 7, 9, 10, 11 and 12).

Loyola Corners is and should remain unique. It should have its own character and flavor. Its special image should reflect the needs of its nearby residents and its underlying physical organization. This notion prompts the discussion of the need for an area "design theme." The plan does not contain a recommendation for a specific design style or theme or for the consistent use of building colors, materials or forms. The adoption of rigid themes, modes or materials was considered too limiting and restrictive in terms of creative design solutions. Rather, design coordination and unification through the provision of a framework of design guidelines is preferred. The principal goal is to achieve an attractive unified whole without requiring sameness.

Finally, although the planning area has a rich and unique history, no buildings or structures of historical merit exist.

The Loyola Corners area urgently needs some immediate but effective actions in order to generate a positive identity and to make the area more attractive to shoppers. A quick-results clean-up, paint-up campaign adding "instant landscaping", restriping the central parking area, and screening the trash receptacles is needed to demonstrate initial results and establish a new momentum. Longer term actions needed include: permanent landscaping, coordinated color palettes for buildings, coordinated signs, unifying architectural features such as awnings, taking advantage of Permanente Creek, more clearly defining street and pathway edges and undergrounding utilities.

The Central Triangle needs to become the design as well as the functional heart of the area. Careful design attention will be required to ensure that the space functions as an inviting pedestrian plaza as well as a parking area. The buildings along Fremont and Miramonte Avenues should be redesigned so that they can be reoriented to the pedestrian as well as to Fremont and Miramontes Avenue auto traffic.

In addition to the provision of focus, there is a need to provide vistas into the area from adjacent streets and walkways in order to attract shoppers. The Plan contains recommendations to create peripheral public plazas for these purposes.

#### Policies and Standards:

- DB- 1 Coordinate use of buildings materials, colors, awnings, signs, pathways, paving, street furniture, lighting, landscaping and define street and pathway edges to create a harmonious whole. (see Figures 4, 9, 10, 11 and 12).

- DB- 2 Initiate a "quick-results" design and clean-up program to establish a new identity and a sense of momentum for the center.
- DB- 3 Create public plazas to encourage use of the area by customers and to create a sense of destination (see Figures 4 and 10).
- DB- 4 Use architectural features (such as sculpture, clock or sign tower, signs) to create focus and identity (see Figure 11).
- DB- 5 Redesign existing rear parking area of Central Triangle to achieve a pleasant and functional pedestrian and parking plaza (see Figure 4).
- DB- 6 Design and organize special area for trash receptacles.
- DB- 7 Where possible, recognize the existence of Permanente Creek in future planning for businesses east of Miramonte Ave.
- DB- 8 Redesign stores facing Fremont and Miramonte Ave. to provide access to the central pedestrian and parking plaza whenever possible.
- DB- 9 Provide clearly identifiable edges separating traffic, pedestrian land use, landscaping and service functions.
- DB-10 Modify existing overhead electrical and utility distribution system to provide for undergrounding.
- DB-11 Create an architectural and site planning review board to implement design policies of the Specific Plan.
- DB-12 Adopt design guidelines and standards containing the following policies and criteria:

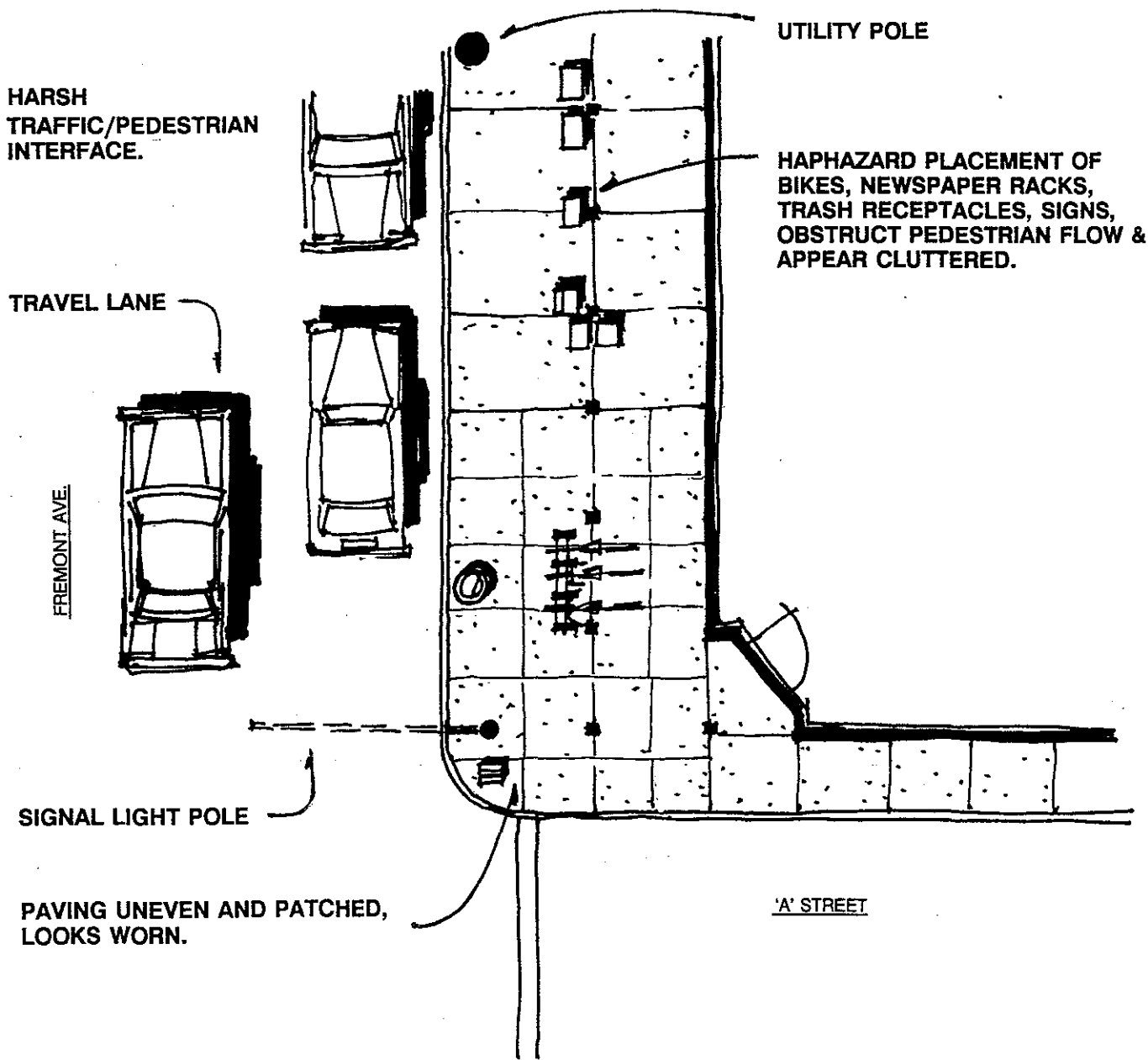

**FIG. 8 EXISTING TYPICAL CORNER**

Source: Donald A. Woolfe & Associates  
 Hardesty Associates, Landscape Architects

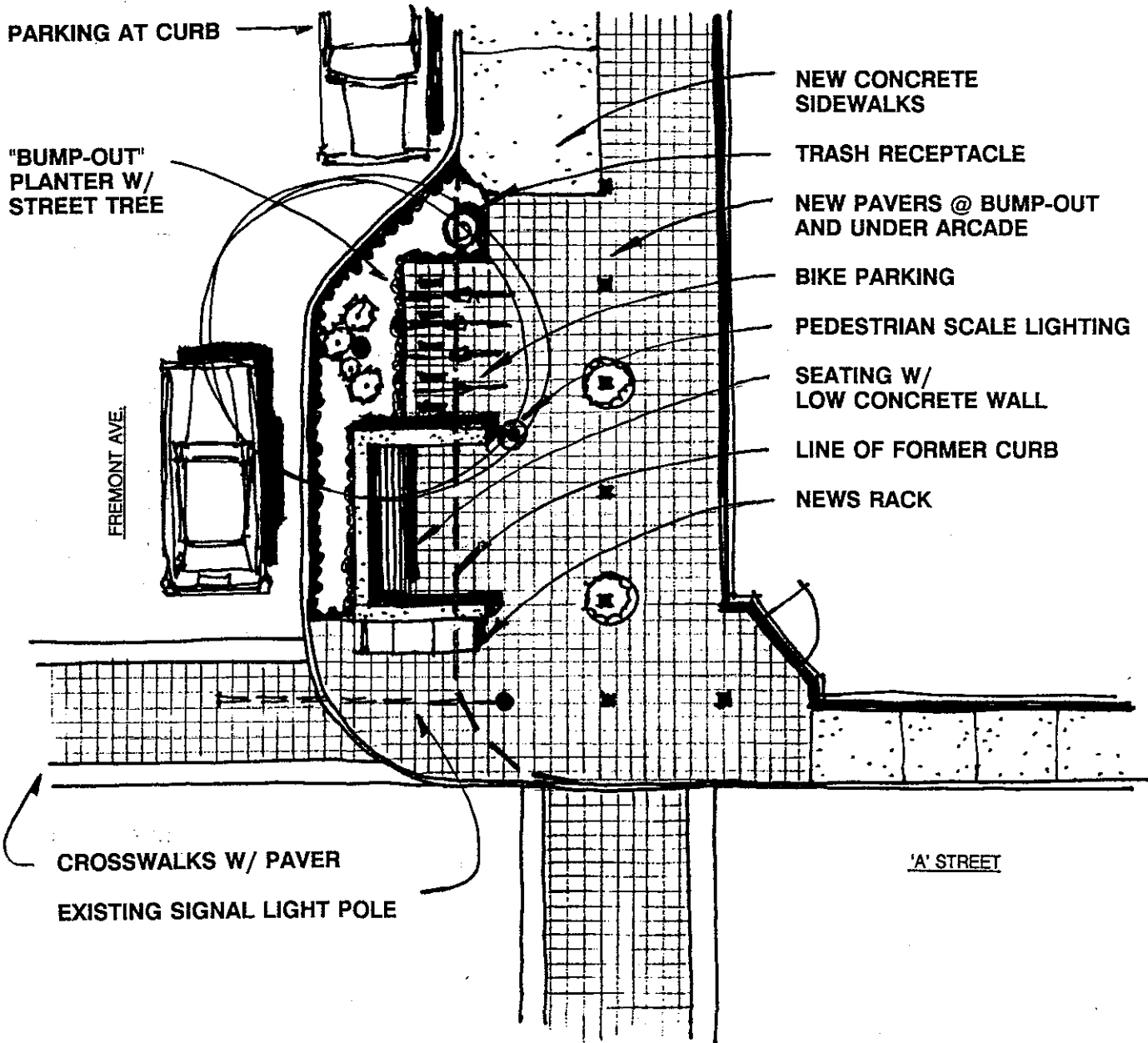

**FIG. 9 TYPICAL CORNER "BUMP-OUT"**

Source: Donald A. Woolfe & Associates  
 Hardesty Associates, Landscape Architects

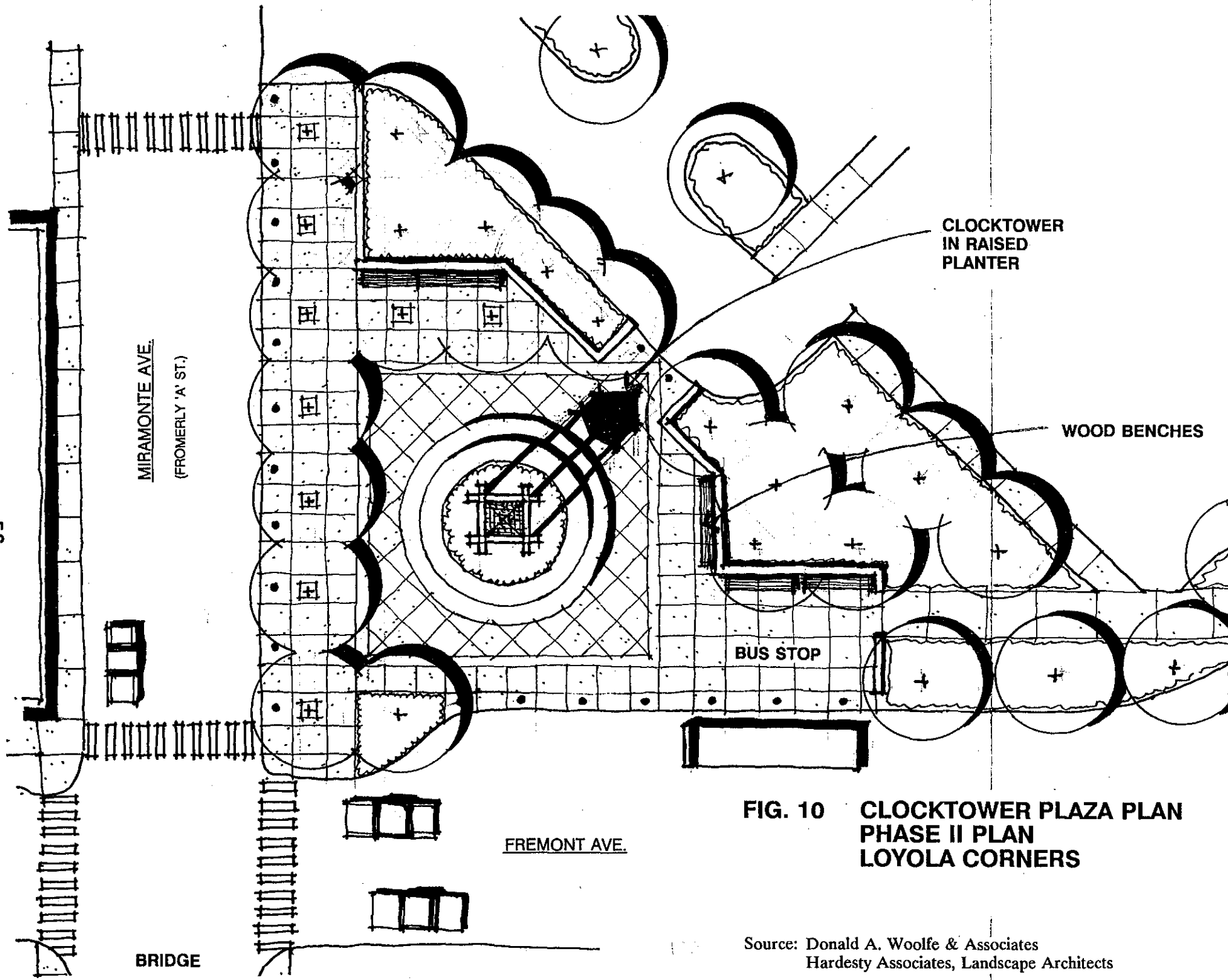

**FIG. 10** CLOCKTOWER PLAZA PLAN  
PHASE II PLAN  
LOYOLA CORNERS

Source: Donald A. Woolfe & Associates  
Hardesty Associates, Landscape Architects



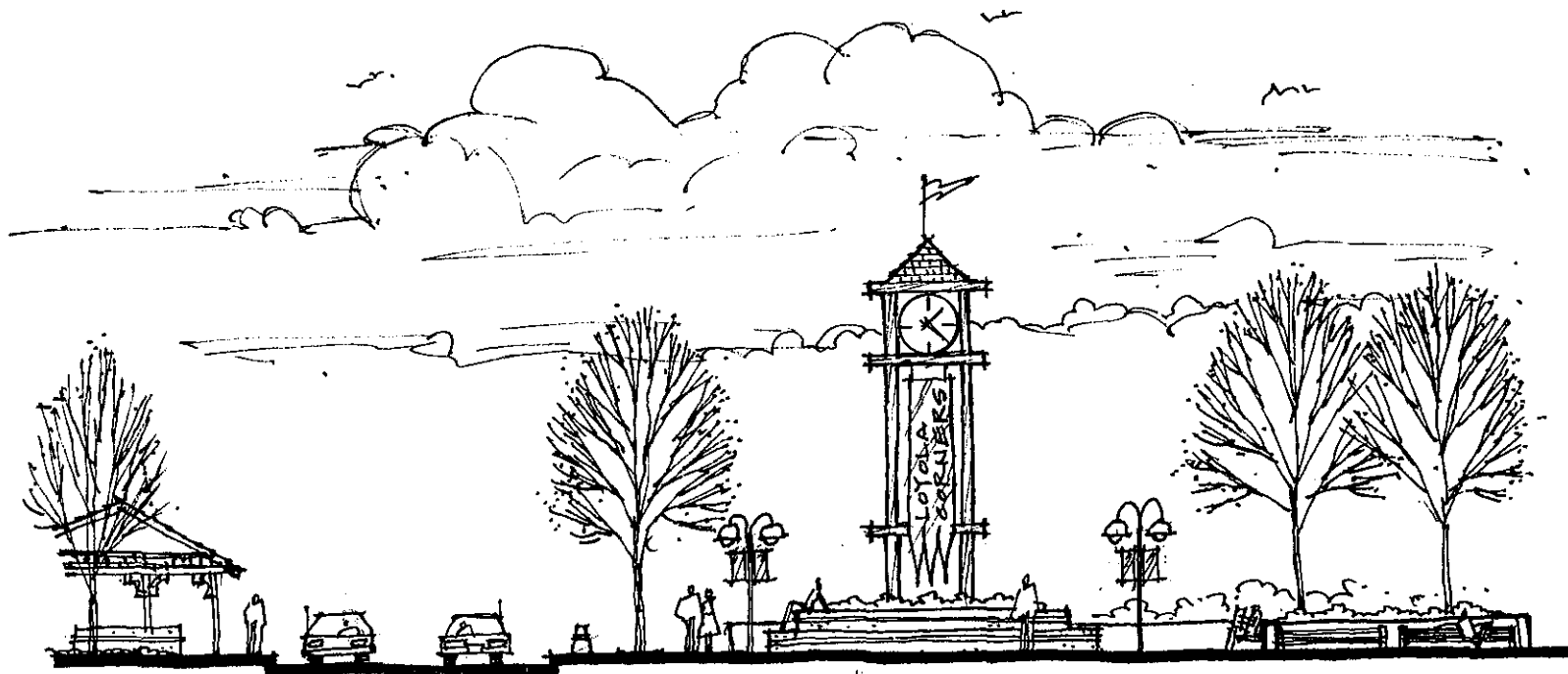

MIRAMONTE AVE.  
(FORMERLY 'A' ST.)

CLOCKTOWER WITH  
"LOYOLA CORNERS"  
BANNERS

WOOD BENCHES

BUS STOP

RAISED SEATWALL  
PLANTER

**FIG. 11**    **CLOCKTOWER PLAZA ELEVATION**  
**PHASE II**  
**LOYOLA CORNERS**

Source: Donald A. Woolfe & Associates  
Hardesty Associates, Landscape Architects

a) Architectural Design

- 1) Architectural character should be informal and unpretentious.
- 2) The size and mass of structures and building elements should be moderately small, reflecting a human scale.
- 3) Since the construction of new buildings and major renovations will be limited, the major design concept is to achieve attractiveness and harmony through unification of disparate parts. This will be achieved through the use of colors, materials, landscaping, and attached elements such as awnings, signs and lighting (see Figs. 12 and 13).
- 4) The original design of certain older buildings should be respected if they are to be renovated. Building modifications should include the entire structure so that the structure remains a coherent whole. Adding unrelated facades or fragments adds to the chaotic character.
- 5) Design of new buildings, additions and other renovations should be compatible in terms of scale, color and materials with surrounding structures.
- 6) Because it is so important to ensure careful integration of any new or remodeled structures into the overall design concept, all designs shall be prepared by licensed design professionals qualified to perform the work.
- 7) Roofs should be limited to simple forms and materials which tend to visually tie structures together rather than produce discord.

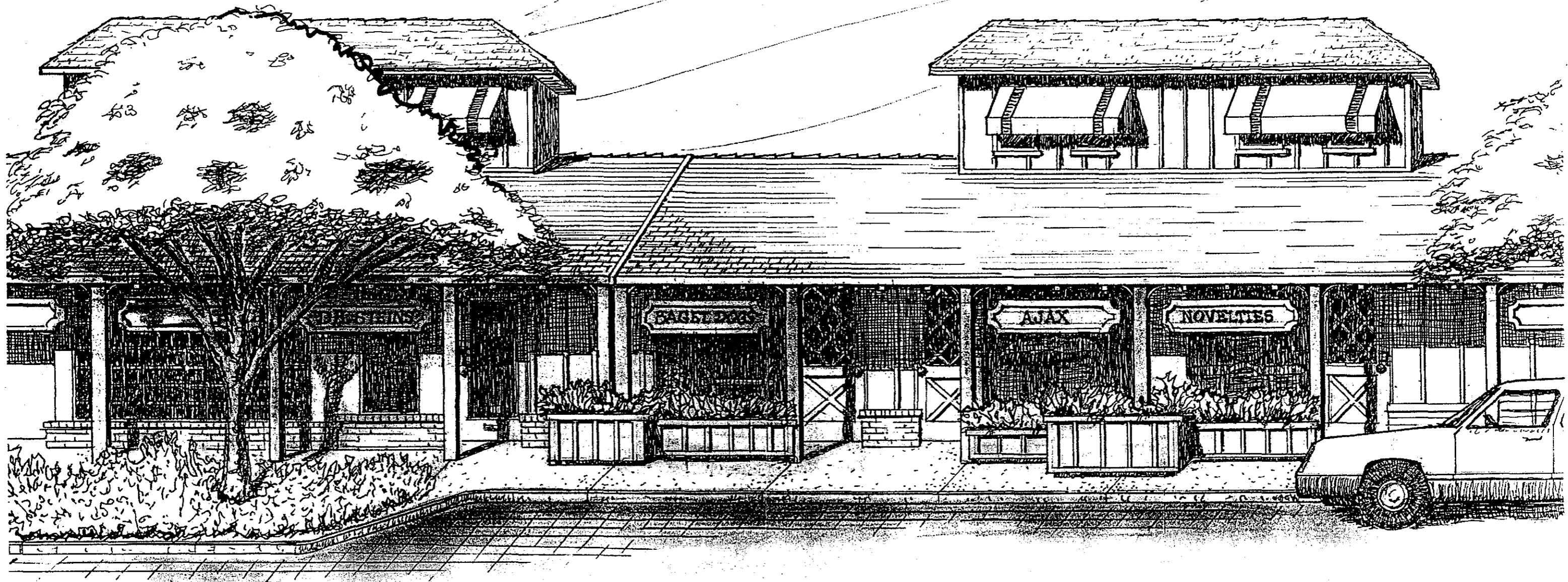

Source: Donald A. Woolfe & Assoc.

Fig.12 Proposed Elevation at Fremont Avenue



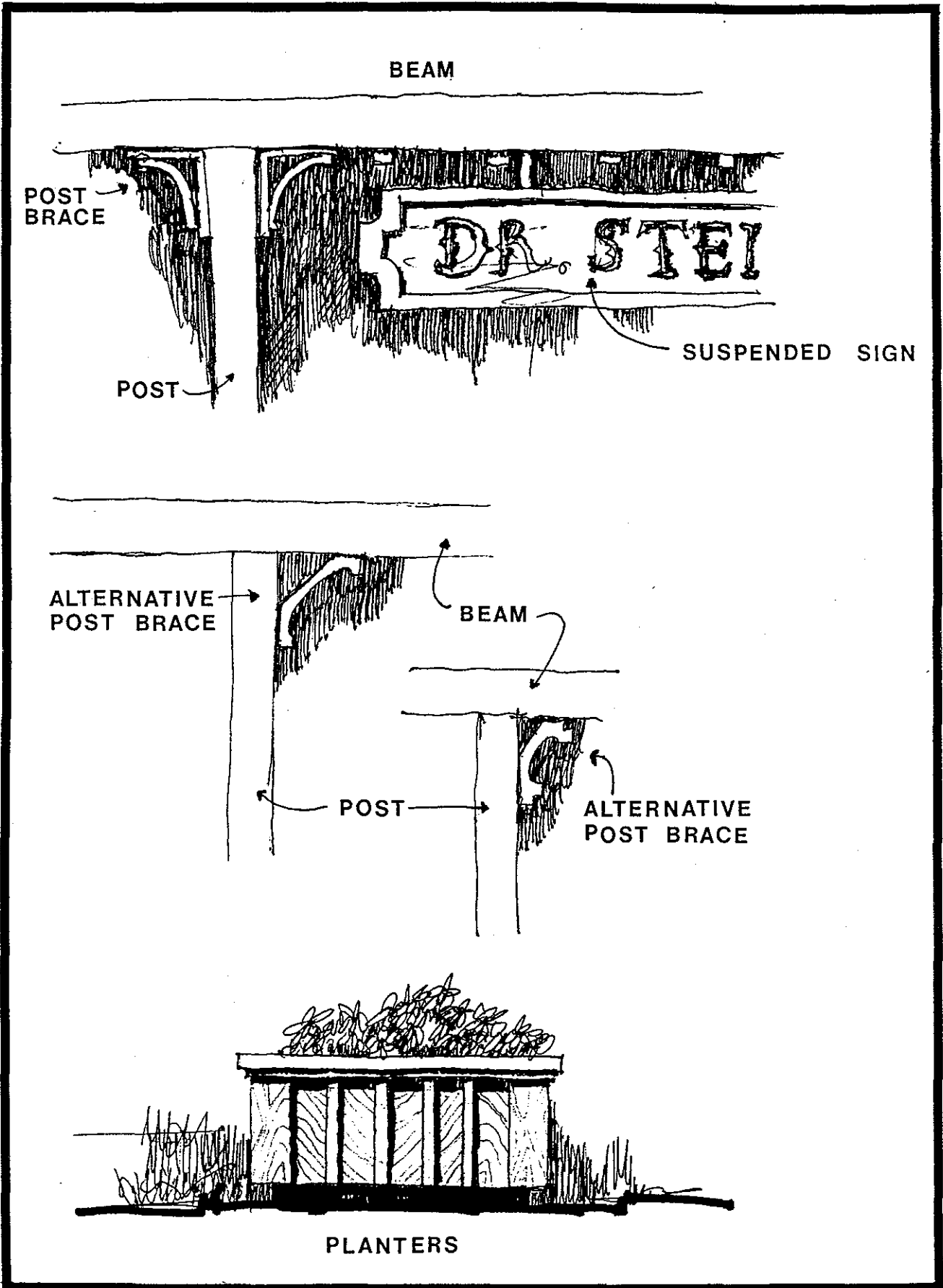

Proposed Design Details

Fig. 13

b) Building Materials - Basic building materials should be conducive to maintaining a small scale, warm, human quality. Exclusive or excessive use of glossy "high tech" or "machine age" materials such as glass block, porcelain-enamel, metallic surfaces, chrome and plastic should be avoided. Second floor glass surfaces should be subordinated to solid wall surfaces.

c) Colors

1) Building color palettes should essentially be monochromatic, highlighted by a limited use of bright, colors for accessories such as awnings and signs.

2) In general, wall colors should be muted (organic) earth tones on painted surfaces, or natural materials such as brick or stone.

3) Use of intense white or very light colors should be avoided (especially on large surfaces).

4) Building trim should be painted the same color, but in a lighter or darker tone than the building walls in order to give emphasis to building form and scale.

d) Signs

1) The size, scale and location of individual buildings signs shall be selected so that the sign is read primarily by pedestrians.

2) The area should have at least one larger, central focus "theme" sign or architectural feature such as a clock tower/sign to be read from Foothill Expressway.

3) Flashing, moving, internally illuminated (plastic) and

neon tube signs shall be prohibited.

4) For buildings with multiple tenants, a coordinated sign program shall be required in order to avoid visual chaos.

5) The maximum height of free standing signs shall be four feet.

6) All signs shall be designed and located to be compatible with and subordinate to the architectural character of the building. Wall signs shall be integrated into the architecture of the building walls. The use of coordinated wall graphics such as murals should also be encouraged. Exotic supergraphics shall not be permitted.

7) All commercial signs shall be located within the first story.

8) The design of all signs shall be as simple as possible in lettering, color and logo design. The use of simple serif letters should be encouraged rather than the use of overly ornate or exotic letters.

9) Applied letters rather than painted letters should be used if sign is to be located on primary building surfaces.

10) Small pedestrian-oriented signs may project from buildings, however a sidewalk elevation clearance of seven and one-half feet must be maintained. Front edge or end panel awning signs may be permitted. Small signs may be suspended from awnings if they are perpendicular to the primary building wall.

11) Neon signs of historic merit such as the Echo, Moms, and Loyola Liquors shall be retained.

e) Awnings - The use of awnings is envisioned as a principal unifying visual element. Hence, a coordinated awning program regulating size, shape, color, material and location is necessary in order to ensure harmonious appearance.

f) Covered Arcade - The existing covered arcade along Fremont Avenue shall be retained as a principal unifying design element. The addition of "decorative" knee braces at post and planters will enhance the design image.

g) Lighting

1) Night lighting should be provided as appropriate for safety on pedestrian walks and parking areas.

2) Exterior light sources should be shielded from view from adjacent residential properties and streets.

3) Intensity shall be limited to that necessary for safety identification.

4) Lighting hues shall be warm rather than cool colors.

h) Landscaping

1) Landscaping should be used to achieve visual unity; trees shrubs and other large plant materials, containers or planting areas should be selected, designed and located to become part of an overall design concept.

2) Landscaping should be used to establish a pleasant setting for structures, screening of service and parking areas, and to soften the appearance of building elements and paved areas.



- 3) Landscaping should also be used to define walkway and street edges on public outdoor areas.
- 4) Shade trees should be utilized in main parking/pedestrian plaza areas to the maximum extent feasible.
- 5) Provide new trees and landscaping to buffer residences facing Loyola Corners.
- 6) The character of landscaping and related materials should be suited to the architectural character and scale of the center. Landscaping should also be selected to reflect weather, soil conditions, exposure to sun and wind, maintenance and safety considerations. Native materials should be used whenever feasible.
- 7) Provide landscaping for a minimum of 12% of gross parking area within the main parking/pedestrian plaza.
- 8) Minimum sizes of landscape materials shall be 15 gallon tubs for trees and 5 gallon tubs for shrubs.
- 9) Make provision for irrigation systems for all planting areas.
- 10) With the exception of noxious plants and weeds such as poison oak, existing vegetation along Permanents Creek should be carefully protected and additional planting provided as appropriate.
- 11) The areas of vegetation along the creek together with other landscaped areas and public plazas and open areas should form an "open space system" linking the various parts of the center.

i) Paving

1) Paving materials such as concrete, tile, brick and asphalt should be used to achieve visual unity, provide visual interest and define functions such as walkways, parking areas, building entrances, etc. Also, similar to the use of plant materials, paved areas and circulation links should constitute an overall coordinated paving system which coherently links the various parts of the center.

2) Paving materials should be selected to be compatible with the area's architecture and landscaped areas.

3) When selecting paving materials, the long-wearing and low maintenance varieties should have first preference.

j) Street Furniture

1) Provide benches, newspaper and magazine racks, bicycle racks, trash containers , telephones and street furniture in convenient areas.

2) Similar to the other design elements, the design, construction and location of street furniture should represent a unifying feature throughout the center.

3) Street furniture should be compatible with the architectural character of the area and should be selected for appropriateness of materials, safety, maintenance and resistance to vandalism.

k) Utilities

1) All overhead utilities serving the planning area should be undergrounded.

2) All new buildings, additions and major renovations should make provision for underground service.

3) Surface utilities such as transformers, utility boxes, vaults, etc. should be located in areas of low visibility and where possible, behind screens or landscaping or integrated into the building design.

**V IMPLEMENTATION** (See Figure 14 - Implementation Diagram)

**A. Table 2- Specific Actions and Responsibilities for Action**

<u>Action</u>	<u>Timing</u>	<u>Responsible Group</u>
PHASE IA	1 - 6 months	
1. Appoint a person to coordinate all actions .		City
2. Establish a joint City, business and property owners program for coordinating painting, signs, awnings and other private property improvements.		City and Loyola Corn. Bus. Assn.
3. Form Business Improvement District		Loyola Corn. Bus. Assn.
4. City clean up and restripe parking area in Central Triangle. Screen trash receptacles, bring in temporary landscaping.		Bus. Impro. Dist.
5. City to increase enforcement of parking regulations on residential streets and speed regulations on Fremont and Miramonte Aves. during commute hours.		City
6. Establish Loyola Corners Study Committee as plan support committee to work with Parking District and other City agencies, residents and businesses as a Plan support group.		City
6. City to rezone property on Miramonte at Dolores Ave. from residential to commercial with adequate buffering for adjacent residences.	1st 12 months	City

PHASE IB	1 - 3 years	
1. City to form Parking Assessment District. Task is to complete final design, raise funds, oversee construction of improvements and manage the ongoing implementation of the Loyola Corners Specific Plan.	12-18 months	City
2. Parking District to reorganize and increase the number of parking spaces in the Central Triangle area, relocate trash receptacles, and construct permanent landscaping of the parking plaza area along bordering streets and bordering residential areas.	12-24 months	Parking District
3. Parking District to work with businesses and property owners to open up rear of stores facing onto central parking and pedestrian plaza. Create special pedestrian plaza in area behind Fremont stores.	Follows IB-2	Parking District and Business Improve. District
4. Parking District to work with Loyola Corners Business Assoc. to move Farmer's Market into the central plaza.	Spring 1991	Parking District & Business Imprv. Dist
5. Parking District and other City agencies to work with U.S. Postal Service to arrange for landscaping and other visual improvements at Post Office distribution site.	Uncertain	City and Parking District
6. City to create new zoning district for Loyola Corners incorporating revised parking standard and other regulatory revisions ,if required ,to allow modest expansion. District provisions also to require use permits for new structures, additions and renovations.	1st 12 months	City

7. Under new zoning provisions, City to allow expansion up to 23,000 sq. ft. (15,000 sq. ft. in retail, 4,000 sq. ft. in retail services, and 4,000 sq. ft. in office uses),	Follows new zoning (IB-6)	City
8. City to simplify traffic flow around the traffic island at Fremont, Miramonte and "A" Streets. Monitor results to see if modifications are needed.	1st 12 months	City
9. City to identify mitigation measures for traffic on Loraine Street, starting with signs to control truck traffic. Monitor results to see if modifications are needed.		City
10. Parking District to acquire and remove existing vacant beauty shop facing Dolores Street. Use property to improve access to parking and for parking spaces.	Depends on funding	Parking District
11. Parking District to acquire photo store on traffic island at Fremont and Miramonte Aves and "A" St.	Depends on Funding	Parking District
12. Parking District to realign Miramonte Ave. to existing "A" Street location to provide additional area for new plaza (see IB-12 above).	Coordinate with IB-12	Parking District
13. City to allow mixed retail and housing development on Bank of America parking lot parcel. City to require additional landscaping and screening to protect adjacent residences.	Follows approval of new zoning regs. (IB-6)	City
14. City and Parking District to work with U.S. Postal Service to establish a full service post office at the site.	Uncertain	City and Parking District

- |   |            |   |
|---|------------|---|
| 15. City and Parking District to work with appropriate sources to initiate undergrounding of utilities. All new buildings will be designed to receive undergrounded utilities.          | Uncertain  | City and Parking District                 |
| 16. Loyola Corners Business Improvement District to continue to support Plan through projects to continue to maintain properties, support promotions for center and related activities. | Continuing | Loyola Corners Business Improve. District |

<u>Action</u>	<u>Timing</u>	<u>Responsible Group</u>
PHASE II		
1. Parking District and Santa Clara County Transportation Agency to widen bridge over Foothill Expressway to provide for an added traffic lane as well as pedestrian and bicycle movements. Widen right of way of existing "A" St.	Depends on funding	City, Parking District, Santa Clara County Transport. Agency
2. Parking District and Santa Clara County Transportation Agency to relocate northbound on-ramp to a hook ramp at the foot of Dolores Avenue.	Depends on funding	Same
3. City to change Fremont from one-way to two-way traffic. City to designate Dolores Avenue one-way from Fremont Ave. to Miramonte Ave. Santa Clara County Transportation Agency to realign bus route from Dolores Avenue to Fremont Avenue.	Depends on relocation of on-ramp (See II-2)	City and Santa Clara Co. Transp. Agency
4. City and Parking District to work with property owners to establish a pedestrian walkway and small pedestrian plaza on portions of the present Beacon Oil Co. site. The pedestrian walkway linking the Central Triangle to the Bank of America properties would be aligned along the Dolores Avenue portion of the site. The pedestrian plaza at the corner of Dolores and Fremont Avenues would predominantly use land now used for sidewalks and landscaping.	Depends on funding	City and Parking District & Business Improvem. District



- |  |                    |   |
|--|--------------------|---|
| 5. City and Santa Clara County Water District to cooperate in establishing a linear park along Permanente Creek. Park would recognize needs of existing businesses and residents adjacent to the Creek. Any new construction along the Creek would be required to reflect the anticipated Creek park in its plans. | Depends on funding | City and Santa Clara Co. Water District & Business Improvem. District |
| 6. City to work with U.S. Postal Service to bring the post office site back into private retail use  | Depends on funding | City and Business Improvem. District                                  |

Note: The reorganized Loyola Corners Support Committee will monitor and review progress on all phases of implementation.

**B. Planning and Zoning Regulations**

While the City's General Plan is intended to provide a generalized comprehensive and long range planning strategy for the physical development of the City, the completed Specific Plan reflects the specific local, three dimensional issues and nuances of the planning area. A Specific Plan is intended to represent a more detailed customized approach to the comprehensive resolution of planning problems. Therefore, in order to realize the more specific policies and planning proposals included in the plan, a departure from conventional zoning solutions is necessary. This is so because most often traditional zoning applications, based on city-wide policies, do not provide for the special or unique design standards and customized innovations found in more detailed plans.

Therefore, this Plan includes a recommendation to formulate individual Specific Plan zones (i.e. SPZ/LC = Specific Plan Zone/Loyola Corners) which are designed solely to implement the proposals and policies contained in the Specific Plan. Although the essential format of the zoning text for these districts would be similar, the development standards might differ from one planning area to another. It is recommended that each applicant for development (whether said development requires a building permit or not - i.e.

for signage, awnings, paving, landscaping, painting, etc.) be required to secure a special use permit which would assure: 1) that any proposal for area improvements or maintenance would be consistent with the provisions of the Specific Plan, and 2) the City's ability to apply a range of reasonable conditions of development to each proposal, again to ensure plan compliance. In implementing a Specific Plan of this nature (involving multiple land owners and several independent businesses) the adopted plan serves as the common planning denominator. The allowance of (what may appear to be) minimal departure from the plan (i.e. colors, landscaping, signage) may result in the unraveling of a carefully conceived community design strategy.

Also, it may be necessary to amend the General Plan to provide for the differing development standards (such as parking) within the SPZ zones.

In order to implement the special use permit procedure outlined above a number of City-initiated actions are required as follows:

1. Establish an architectural and site planning review board for Loyola Corners.
  
2. Adopt specific design guidelines and mandatory design standards (see DB-12) for use by project applicants, City staff and review board (i.e. for acceptable range of building colors and materials, landscaping, signs, etc.)
  
3. Provide an incentive for plan compliance by adopting a procedure to expedite permit issuance when included proposals are deemed to be consistent with the Specific Plan.

Non conforming buildings and uses are those which conformed to the regulatory ordinances in effect at the time of their creation but which do not conform to the current ordinances. They are pre-existing legal uses. These uses may be continued as long as the landowner's rights of use are proven. Proof or vesting is achieved by conclusively demonstrating a lawful, actual and continuous use of the building or property. Non-conforming uses may be maintained "in place" (repairs only) but may not be expanded. In general,

non-conforming uses may be terminated through 1) destruction of structure, 2) abatement as a public nuisance, or 3) the establishment of a reasonable amortization period.

The planning area contains some non-conforming uses (i.e. office uses on ground floor and non-conforming signs). The issue of the final disposition of non-conforming uses will be addressed within the context of the Specific Plan Zoning District which will be created subsequent to the adoption of the Specific Plan.

**C. Estimated Costs for Specific Plan Program, by Phases:**

PHASE IA Clean-up, paint up program, restriping parking areas and temporary landscaping.

-Private refurbishing, painting, etc.

-Total Estimated Cost = \$40,000 to \$45,000

PHASE IB Street improvements, new curbs and gutters, changing traffic flow around island at Miramonte and Fremont Avenues and "A" Street. (\$132,000)

-Start-up costs for establishing Parking District, including legal engineering and E.I.R. (\$50 to \$80,000).

- Repaving pedestrian/parking plaza, acquiring vacant beauty shop, constructing landscaped "bumpouts", permanent landscaping, relocating trash receptacles.(\$100 to \$300,000).

- Private renovations, awnings, signs, etc.

- Total Estimated Cost - \$650,000 to \$1,000,000

PHASE II -Street improvements, widening bridge, relocating on-ramps,  
restoring two-way traffic on Fremont. (\$936,000).

-Acquire and/or relocated Photo Drive-Up store and build  
pedestrian plaza.

-Acquire easement and relocation Beacon Oil Gas Station office  
and build pedestrian plaza.

-Construct pedestrian pathways and additional landscaping for  
Maple Lane and Loraine Avenue.

-Total Estimated Cost = \$530,000 to \$2,500,000

Note: These costs are preliminary estimates intended to provide an overall  
sense of total program magnitude. Actual costs may vary considerably  
based on type of construction, quality of materials, current market  
conditions and other factors.

**D. Recommendations for Financing and Organizing to Carry Out  
the Program.**

1. Establish a Parking Assessment District or similar organization. The  
City should establish an organization to fund the public improvements  
which will serve the area including parking, permanent landscaping,  
curbs and landscaped bumpouts and traffic improvements.
2. Establish a Business Improvement District.  
The existing Loyola Corners Business Association is a non-profit  
corporation with tax-exempt status. This association should request the  
City of Los Altos to join them in establishing a Business Improvement  
"Benefit" District and take the necessary steps to implement the Benefit  
District. The Benefit District can provide the funds to continue the  
Farmer's Market and other promotion and assistance programs for

businesses in the area. The Benefit District should take as its first order of business, the immediate clean-up campaign for the area. Since it will take some time for the Benefit District to raise funds, the District should request the City to participate on a 50-50 basis for funding improvements. The District should also request the City to loan start-up funds which the District will repay over a time period which permits annual assessments affordable to the businesses and property owners.

3. Establish a Loyola Corners Support Committee.

Continue the Loyola Corners Study Advisory Committee with the assignment to continue to support Loyola Corners and Implementation of the Specific Plan.

4. Underground Utilities

The City should request P.G. & E. to include the Loyola Corners area in their annual undergrounding program in Los Altos. In addition, any new structures, additions or major renovations should include provisions for underground utility connections.

5. Establish an Annual Capital Improvement Program.

The various public improvements that cannot be accommodated in the Parking District program (such as the items related to the early improvements to be funded through the Business Improvement District) should be incorporated as part of the City's annual Capital Improvement Program.

6. Provide for Community Development Tax Increment Financing.

The City may elect to finance the improvements and future area improvements using the State Redevelopment Act. The act provides for much more flexible financing and may be the vehicle through which the private parcels called for in the Plan would be acquired for the public easements and plazas. A number of legal steps must be followed to use this financing tool but it has potential for large long term financial benefit.

7. Provide for declaration of "Public Need and Necessity."

This may prove to be the appropriate way to acquire the lands needed for traffic improvements, including realigning Miramonte Avenue.

8. Mello-Roos Bonds

This is a technique for pooling small bond issues to save overhead costs on their sale and to achieve better interest rates. Parking District improvements might be financed using this device.

# LOYOLA CORNERS \* SPECIFIC PLAN IMPLEMENTATION DIAGRAM

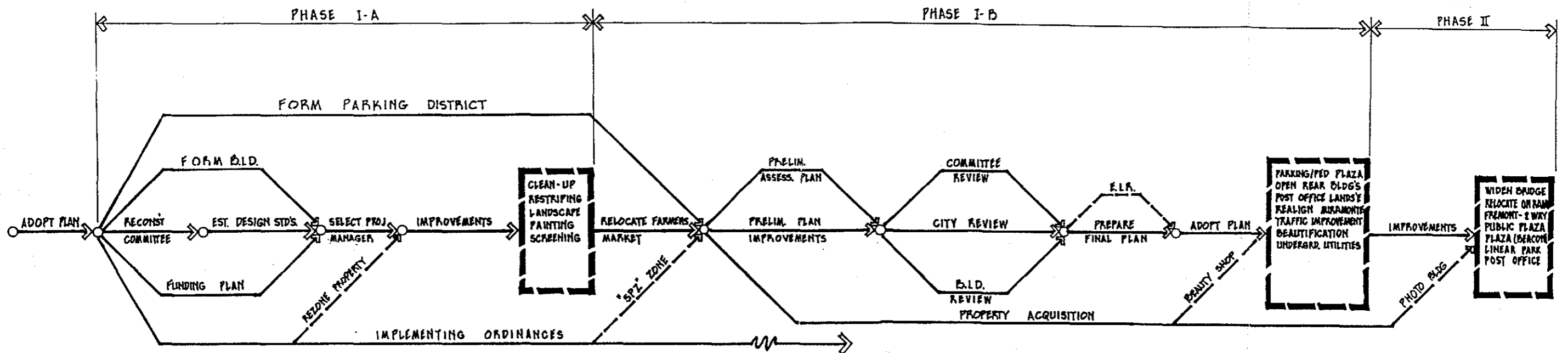

Fig. 14

DONALD A. WOOLFE & ASSOCIATES

## TECHNICAL APPENDIX A

### Loyola Corners Specific Plan - Circulation/Traffic Analysis

#### EXISTING CONDITIONS

Traffic flow at Loyola Corners is complicated by the awkward design of the local street system and its connection to the Foothill Expressway. There are several traffic movements that must make unnecessary turns and pass through extra points of traffic conflict. These inefficient traffic movements would not be needed if the street system was better designed.

The most awkward existing traffic movement is north on Loyola Drive to east Fremont Avenue which requires traffic to pass through three intersections, Fremont at A Street, A Street at Miramonte and Miramonte at Fremont, rather than simply making a right turn where Loyola Drive crosses the bridge and meets Fremont Avenue. The narrow bridge which carries Loyola Drive to this intersection does not have sufficient space to store vehicles waiting for a green light and causes traffic to back up across the bridge and to occasionally block the intersection of the southbound Foothill Expressway ramps and Loyola Drive. The design of the northbound ramps to and from the Expressway requires that the most important commercial street at Loyola Corners, Fremont Avenue, be operated as a one-way frontage road.

The operation of each of the important intersections in Loyola Corners in the afternoon peak hour is shown on Table 1. The efficiency of intersections is measured by traffic engineers in terms of Level of Service. Service levels A or B indicate little delay for motorists. Service levels E and F indicate severe congestion and long delays. At Level of Service D motorists may occasionally have to wait through more than one green light. Level C is often set by smaller cities as an appropriate standard for planning purposes.

As shown on Table 1 there is no significant delay experienced at any one of the intersections in Loyola Corners under existing traffic loads. Most of the frustration experienced by motorists at Loyola Corners is based on the number of intersections too closely spaced from one another and on the awkward layout of the street system.

The intersection where the greatest delay occurs is at A Street and Fremont Avenue where the afternoon peak hour service level is level B. While the delay at this intersection is not great, about 15 seconds per average vehicle using the intersection, the limited capacity of the bridge to store vehicles waiting for a green light causes an unnecessarily lengthy queue to form and to occasionally block the intersection on the south side of the bridge. All other intersections operate at Level of Service A in the afternoon peak hour.

Traffic generated by the existing commercial development at Loyola Corners represents about 21% of the total traffic using the local street system.



-----  
 TABLE 1

INTERSECTION LEVEL OF SERVICE (LOS) AND VOLUME TO CAPACITY RATIO (V/C)

Existing Streets and Intersections

Intersection	Existing Traffic		Build Out Traffic	
	LOS	V/C	LOS	V/C
Fremont Avenue at A Street/Loyola Drive	B	0.68	B/C	0.70
Fremont Avenue at Miramonte Avenue	A	0.57	A/B	0.60
Fremont Avenue at Dolores Avenue	A	*	A	*
Miramonte Avenue at Dolores Avenue	A	*	A	*
Miramonte Avenue at A Street	A	*	A	*
Miramonte Avenue at B Street	A	*	A	*

\* V/C Ratio not calculated for stop sign controlled intersections.

Source: Robert L. Harrison

-----

BUILD OUT TRAFFIC

The Loyola Corners Specific Plan calls for the addition of up to 23,000 square feet of retail and office space in the commercial area. The trip generation which would be added by the increased commercial space is compared to the existing Loyola Corners trip generation in Table 2.

The Build Out traffic would be an increase of 1,620 daily trips or 24% from the existing daily trip generation at Loyola Corners. Afternoon peak hour trips would increase by 120 trips or 19% from existing conditions. Assuming no increase in traffic from any other new development, the increased trip generation due to the build out of the commercial area would raise the share of the traffic on the local street system which is generated by the Loyola Corners commercial area from 21% to 24%.

The afternoon peak hour Level of Service at each intersection assuming the build out of Loyola Corners and assuming NO change in the existing street patterns or capacities is shown in Table 1. The added traffic would decrease

intersection Level of Service by about 1/3 of a service level letter grade. For the most congested intersection at A Street and Fremont Avenue service level would drop from B to B/C. The intersection of Fremont and Miramonte would drop from A to A/B. None of the intersections would operate at unacceptable levels of congestion due to the addition of build out traffic. Improvements to the existing street system as recommended in the Specific Plan would fully mitigate the impacts of increased trip generation which would result from the build out of Loyola Corners.

-----  
TABLE 2

LOYOLA CORNERS - EXISTING AND BUILD OUT TRIP GENERATION

	Daily Trips	Afternoon Peak Hour Trips		Total
		Inbound	Outbound	
Existing Development (Excludes Post Office)	5,850	255	285	540
Post Office (Estimate)	850	20	60	80
Totals	6,700	275	345	620
Increased Commercial Space (23,000 sq.ft.)	1,620	55	65	120
Total Trip Generation at Build Out	8,320	330	410	740

Source: Trip Generation, 4th Edition, Institute of Transportation Engineers.

-----

STREET IMPROVEMENTS

The Loyola Corners Specific Plan recommends two phases of street improvements intended to serve the traffic growth generated by the added commercial development and to serve increased through traffic flow. The design for the improved street system at Loyola Corners is based on the following criteria:

- 1 - The number of traffic conflicts should be minimized and the efficiency of the street system should be maximized wherever possible.
- 2 - The safety of local streets should be improved, especially for pedestrians and bicycles.
- 3 - The street system should help locate and define the community including the street intersection which would be known as "Loyola Corners".

An analysis of the existing traffic conditions at the six most important intersections in the local street system resulted in a finding of the total number of existing traffic conflicts. Traffic conflicts are defined as the point where vehicles need to cross one another in an intersection. For example, a left turn versus opposing through traffic. It is the number and magnitude of these conflicts which determine the amount of green time which must be assigned to each turning movement and thus establish the parameters for the design of the signal control at an intersection.

The existing traffic conflicts were compared to the number of conflicts which would result under each of six alternative designs for changing traffic flow on the local street system. The street improvements which produced the greatest reduction in traffic conflicts relative to the cost of the improvement were selected for the Plan. The cost of the alternative improvement schemes was determined and a plan for phasing the street improvements was developed. Each phase of the recommended street improvement plan and its approximate cost are described in Table 3 below.

-----  
 TABLE 3

LOYOLA CORNERS TRANSPORTATION PLAN

=====

- Phase IA	COST - \$ 5,000
Delineate pavement edges and parking spaces - (Paint pavement edges and parking areas)	
Construct safe pedestrian routes - Paint pedestrian bike paths	
Improve sight distances at intersections.	
- Phase IB	COST - \$127,000
Delineate pavement edges and parking spaces -	
Construct approximately 2,000 linear feet of curb and gutter.	
Construct approximately 2,000 linear feet of sidewalk.	
Provide Street and Traffic improvements -	
Make Fremont 2-way from the bridge to Miramonte.	
Make A Street 1-way south.	
Make Miramonte 1-way north to A Street.	
TOTAL COST OF PHASE I (Phase IA + Phase IB) - \$132,000	
- Phase IIA	COST - \$386,000
Widen bridge to 3 lanes (1 southbound lane; 1 northbound left turn lane; 1 northbound through and right turn lane).	
- Phase IIB	COST - \$550,000
Make Fremont 2-way between Dolores and the bridge (requires loss of some parking and curbside loading space).	
Move northbound on-ramp to intersection of Fremont and Dolores Avenue.	
Reconstruct and signalize intersection of Fremont/Dolores and new ramp.	
TOTAL COST OF PHASE II (Phase IIA + Phase IIB)\$936,000	
TOTAL COST OF ALL PHASES OF THE TRANSPORTATION PLAN - \$1,068.000	

A summary of the analysis of the reduction in the number of traffic conflicts which would be achieved under each alternative traffic pattern for each phase of street improvements is shown in Table 4. From Table 4 it is clear that the greatest improvements in traffic operations would be achieved under alternative C in Phase IB and under alternative F in Phases IIA and IIB. (There would little or no reduction in traffic conflicts due to the improvements included in Phase IA.) A summary of the benefits which would be achieved under each phase of the transportation improvements plan is given in Table 5.

TABLE 4

COMPARISON OF TRAFFIC CONFLICTS UNDER ALTERNATIVE STREET IMPROVEMENT PLANS

Improvement Alternatives	Major Phases of Improvements (1)					
	Phase IB		Phase IIA		Phase IIB	
	Total Conflicts	Gain Over Existing	Total Conflicts	Gain Over Existing	Total Conflicts	Gain Over Existing
A - Fremont 2-way Bridge to Miramonte.	2,225	6%	2,030	15%	N.A.	N.A.
B - Fremont 2-way Bridge to Miramonte. A St. 1-way south.	2,150	9%	2,050	14%	N.A.	N.A.
C - Fremont 2-way Bridge to Miramonte. A St. 1-way south. Miramonte 1-way N.	1,845	22%	1,750	26%	2,105	11%
D - Fremont 1-way E. bridge to Miramonte. A St. 1-way south. Miramonte 1-way N.	2,013	15%	1,915	19%	N.A.	N.A.
E - Fremont 2-way bridge to Miramonte. Close A Street.	2,260	5%	2,260	5%	2,190	8%
F - Close Miramonte. Fremont 2-way from bridge to Miramonte.	2,393	-1%	1,738	27%	1,739	27%

Note 1: See Table 3 for a description of improvements under each phase.

Source: Robert L. Harrison

---

TABLE 5

BENEFITS OF EACH PHASE OF TRANSPORTATION PLAN

---

---

Phase 1A

- Improves safety for pedestrian, bicycles and vehicle traffic.
- Makes parking lots more efficient, easier to use and more inviting.
- Makes walking safer and more attractive throughout Loyola Corners.
- Organizes the edges of traffic and pedestrian/bicycle routes.

Phase 1B

- Improves traffic operations at the intersections of Fremont Avenue and A Street; Fremont and Miramonte Avenues; and Miramonte and A Street.
- Allows for direct routing of traffic from south of the Bridge to eastbound Fremont Avenue eliminating 2 of 3 intersections for these trips.
- Eliminates the intersection of A Street and Miramonte Avenue as a point of traffic conflict.
- Allows for the reduction of space for vehicles and added space for pedestrian and bicycles along Miramonte from A Street to Fremont Avenue.
- Removes all through traffic from Loraine Avenue.

Phase II

- Establishes the intersection of Fremont Avenue and A Street as THE corner in Loyola Corners.
- Further improves the operation of the Bridge and of the intersection of Fremont Avenue and A Street.
- Reduces the length of queues by doubling the vehicle storage space on the Bridge.
- Reduces the traffic on Dolores Avenue.
- Removes the bus traffic from Dolores Avenue.
- Provides for a more logical traffic flow on the main east-west street in Loyola Corners.
- Puts more traffic on the most important business street and removes traffic from a primarily residential street.
- Makes access to the northbound expressway slightly less convenient for through traffic from the east of Loyola Corners.

Source: Robert L. Harrison

---

The operation of the local street system in terms of intersection Level of Service under each phase of street improvements and for both existing and build out traffic conditions is shown in Table 6. The street improvements of either Phase IIA or IIB would fully mitigate the increased trip generation from the build out of Loyola Corners meaning intersection service levels would be improved from existing conditions if these improvements were made.

TABLE 6

INTERSECTION LEVEL OF SERVICE (LOS) AND VOLUME TO CAPACITY RATIO (V/C)

Intersections	Existing Streets & Traffic		Phase IIA Improvements Existing Traffic		Phase IIA Improvements Build Out Traffic		Phase IIB Improvement Existing Traffic		Phase IIB Improvement Build Out Traffic	
	LOS	V/C	LOS	V/C	LOS	V/C	LOS	V/C	LOS	V/C
Fremont Avenue at A Street/Loyola Drive	B	0.68	A/B	0.59	B	0.62	A	0.56	A/B	0.60
Fremont Avenue at Miramonte Avenue	A	0.57	A	0.32	A	0.34	A	0.34	A	0.35
Fremont Avenue at Dolores Avenue	A	*	A	*	A	*	A	0.39	A	0.40
Miramonte Avenue at Dolores Avenue	A	*	A	*	A	*	A	*	A	*
Miramonte Avenue at A Street	A	*	A	**	A	**	A	**	A	**
Miramonte Avenue at B Street	A	*	A	*	A	*	A	*	A	*

\* V/C Ratio not calculated for stop sign controlled intersections.

\*\* No conflicts would occur at this location due to the redesign of the street system.

Source: Robert L. Harrison

## **APPENDIX B**

### **ECONOMIC ANALYSIS - LOYOLA CORNERS SHOPPING DISTRICT**

This summary report is intended to provide a background on the economic issues and forces at work in Loyola Corners, along with recommendations for actions to ensure its economic stability.

#### **Summary**

Loyola Corners has survived the major loss of the Safeway store but has recently experienced declining revenues in a very competitive market place. Positive actions are needed to ensure its continuing stability. Steps needed include better retail mix, moderate expansion and renovation of stores and the shopping environment, and a coordinated approach to marketing and management.

#### **Background and Trends**

The shopping area and some of its stores date back to the days when Loyola Corners was a stop on the interurban railroad. Over the years it has experienced expansion and decline. The most recent event in the history of Loyola Corners was the closing of the Safeway store in 1985. This loss sent a shock through the entire center as retail sales declined 20% or more. Recently, revenues have stabilized and many stores are doing well, but business has never returned to that earlier level.

Some current trends:

1. Sales in the City of Los Altos as a whole, measured by sales tax returns indicate that the City revenue growth remained even with inflation from 1986 to 1989. The strongest sales increases were in food and restaurants. Sales in other sectors such as apparel, slipped modestly over the period (see Table 1).

2. Even after the closing of the Safeway store, Loyola Corners continues to be a strong competitor among the neighborhood centers in the City of Los Altos, as two of the top twenty five sales tax generating businesses in Los Altos are located in Loyola Corners. However area sales are declining while other centers are increasing sales (see Tables 2 and 3).

### **Situation**

1. The trade area provides a strong, affluent market with a total disposable income on the order of \$533M. The customers buy top-of-the-line goods and services (see CMR report).
2. Loyola Corners' stores have strong competition. There are four centers with 54 stores within 1 1/2 miles of the center (see Table 4).
3. Loyola Corners has ;91,000 sq. ft. of buildings. Currently only 43,000 sq. ft. - less than half - are used for retail activities. Most of the competing centers have more than 60,000 sq. ft. in retail stores and up to 97% of that space in retail activities (see Tables 5 and 6).

### **Competition Issues**

1. **Size**  
Loyola Corners has less square feet in retail use at this time than any of its competing centers. An increase in retail square feet is needed to help attract customers.
2. **Retail Mix**  
Most of the competing centers are under one ownership or management structure which controls the mix of stores. This tends to make these centers more competitive. Therefore, careful attention to retail mix is necessary to help meet this competition (see Table 1).



3. **Quality of facilities and amenities**

All of the other centers have newer facilities, a more coherent layout, better landscaping and a more attractive appearance. The Blossom Valley Center is in an aggressive expansion and improvement program.

4. **Marketing**

Most of the other centers are under single ownership which permits coordinated programs for marketing hours and promotions. Coordinated programs would help Loyola Corners stay competitive.

5. **Size of Stores**

The stores in Loyola Corners, reflecting the size and age of the buildings, are typically small. This reflects the character of the center, but small sized stores often have more difficulty in competing, in terms of price and range of goods, with larger stores in competing centers.

**Recommended Actions**

1. Allow modest expansion of the retail stores in Loyola Corners.

A. Newer and remodeled buildings, oriented to the central pedestrian and parking plaza, are needed to maximize the advantages of that area, which is intended to be the heart of the shopping district. New buildings will help establish a sense of momentum and a more attractive shopping atmosphere which is more competitive with other neighborhood centers.

B. New retailers are needed to add to the sense of momentum and augment the retail mix (see #3 below).

2. Encourage a coordinated program for marketing and management of Loyola Corners. The present Business Association or a similar group involving the businesses in the area is needed to help the center compete with neighboring shopping areas.
3. Augment the retail mix seeking growth opportunities that will offer multiple buying opportunities for customers in Loyola Corners. The best growth opportunities for Loyola Corners are to build on existing successes in two areas; specialty foods and the bike/pool + patio store (see Commercial Market Report). Specifically:

A. Loyola Corners now has a well established family owned meat and seafood store, an ice cream shop next door and a growing reputation for its new Farmer's Market on Saturdays. These existing attractions could be augmented by other small scale food related stores such as a specialty bakery, a health food store, a dairy store or perhaps even a year round produce store. Moving the Farmer's Market into the middle of the Loyola Corners center will be vital to the success of this strategy.

B. The bicycle shop and the pool and patio store attract customers from a larger trade area beyond Loyola Corners. The bike store, especially, brings in large numbers of people who could also be interested in purchasing related informal, family clothing or other types of sports equipment such as children's bicycles. Bike shop and pool store customers could also be attracted to food related stores such as a bakery, health foods, produce or dairy.

Most of the other stores in Loyola Corners are well balanced for the trade area, which is expected to continue growing in terms of disposable income.

In summary, the stores with the best potential for growth include:

- Bakery
- Produce store or year-round farmers' market
- Health food
- Dairy products
- Outdoor/informal apparel
- Sports equipment compatible with bike sales such as childrens' bikes.

Other stores and services which appear to have market potential include:

- Copy center/office supplies
- Electrical and furniture repair services
- Post office services - postal facility or within another store

These stores could sustain more than 30,000 sq. ft. of expansion. They could be in keeping with the small scale and individual owner character of Loyola Corners and all could fit within the visual image which will be established in the center.

TABLE I

## LOYOLA CORNERS STUDY

## TAXABLE SALES - LOS ALTOS - 1985-1988

Sales Activities	1985			1988			Ratio 1988 to 1985 \$/Est.
	# Est.	Sales (000)	\$/Est. (000)	# Est.	Sales (000)	\$/Est. (000)	
Apparel	36	\$8,632	\$239.8	32	\$6,286	\$196.0	.82
General Merchandise	5	797	159.4	5	723	144.6	.72
drug stores	5	2,171	434.2	6	2,018	336.3	.77
Food*	19	15,301	2,684.4	18	17,649	3,268.0	1.22**
Package Liquor	8	3,731	466.4	7	2,370	395.0	.85
Eating + Drinking	54	21,966	406.8	52	25,038	481.5	1.18**
Home Furnishings + Appliances	77	10,415	135.3	72	10,928	151.8	1.12
Building Materials	10	5,982	598.2	7	6,510	930.0	1.55**
Auto Supplies	3	496	165.3	4	1,968	492.0	2.98**
Gas Stations	13	17,468	1,343.7	13	15,198	1,169.1	.87
Other Retail	116	34,073	293.7	136	50,261	369.6	1.26**
Total Retail	346	\$121,032	\$349.8	352	\$138,948	\$394.7	1.14
Other Establishments	825	35,282	40.3	860	37,416	40.4	1.00
Total	1,171	\$154,314	\$131.8	1,212	\$176,365	\$145.5	1.10

\* Typically only 30% of food store sales are taxable.

\*\* Increase in sales/establishment exceeded 13% increase in Consumer Price Index 1985-88.

Source: State Department of Equalization, Annual Reports of Taxable Sales for 1985 and 1988. Donald A. Wolfe Associates.

TABLE II

## SALES TAX GENERATED - LOYOLA CORNERS AND SELECTED OTHER CENTERS - 1987-1989

Estimated Sales Tax Generated - By Quarters  
(\$000)

Shopping Area	1987					1988					1989		
	1st	2nd	3rd	4th	Total	1st	2nd	3rd	4th	Total	1st	2nd	3rd
Loyola Corners	20.0	28.0	20.0	23.0	91.0	19.0	21.0	22.0	17.0	79.0	16.0	21.0	20.0
Change from previous year						-1.0	-7.0	+2.0	-6.0	-21.0	-3.0	nc	-2.0
Woodland Plaza	22.0	28.0	24.0	22.0	96.0	23.0	24.0	28.0	25.0	100.0	24.0	29.0	29.0
Change from previous year						+1.0	-6.0	+4.0	+3.0	+4.0	+1.0	+5.0	+1.0
Rancho Shopping Center	15.0	16.0	16.0	18.0	65.0	15.0	15.0	15.0	16.0	61.0	13.0	14.0	20.0
Change from previous year						nc	-1.0	-1.0	-2.0	-4.0	-2.0	-1.0	+4.0
Sherwood Triangle	3.0	4.0	5.0	4.0	16.0	4.0	4.0	4.0	4.0	16.0	8.0	4.0	5.0
Change from previous year						+1.0	nc	-1.0	nc	nc	+4.0	nc	+1.0
Total	60.0	76.0	65.0	67.0	268.0	61.0	64.0	69.0	62.0	256.0	61.0	68.0	74.0
Change from previous year						+1.0	-12.0	+4.0	-5.0	-12.0	nc	+4.0	+12.0

Sources: State Department of Equalization, Hinterliter DeLlamas + Associates, Donald A. Woolfe Associates

TABLE III

TOP TWENTY FIVE SALES TAX PRODUCING ESTABLISHMENTS - 3RD QUARTER 1989

<u>Location</u>	<u>Establishments (Alphabetical order)</u>
Loyola Corners	Beacon Oil Bicycle Outfitters
Rancho Center	-
Woodland Plaza	Lucky Store
Foothill Plaza	-
Downtown	Drager's Super Markets Foothill chevron Gregg's TV + Appliance McElroy Lumber Co. Village Chevron Weststates Pacific, Inc.
El Camino Real	ASK Computer Systems, Inc. Businessland, Inc. Chef Chu's Mandarin Kitchen Dealer's Car Stereo El Torito Restaurant ERA Electronics Los Altos Supply + Garden Center Lyon's Restaurant Pool-Patio N' Things Royal Palace
Grant Road near Foothill	Educational-Industrial Systems, Inc.
San Antonio Rd.	Arco AM/PM
Locations Not Identified	Chevron Automotive NCA Corporation Pac. Tell Info. Systems Safeway Store (Which locations?)

Sources: State Department of Equalization, Hinterliter DeLlamas + Associates,  
Donald A. Woolfe + Associates

TABLE IV RETAIL MIX - LOYOLA CORNERS + NEARBY CENTERS  
 SHOPPING PATTERNS REPORTED BY PARTICIPANTS (23) AT NEARBY RESIDENT'S MEETING APRIL 12, 1990

Store Type	Loyola Corners	Rancho	Foothill Plaza	Woodland Plaza	Blossom Hill Ctr.	Total # Establish.
Apparel	-	3 Children-NR Women-NR Sports-NR	1 Sports-NR	-	2 Women-NR Shoes-NR	6
Gen Merchandise	-	-	-	-	-	-
Drug Stores	-	1 Pharmacy-22%	1 Pharmacy-NR	-	-	2
Food	1 Seafood-Meats-78%	2 Gen. Groceries-56% Bakery-48%	1 Safeway-22%	1 Lucky-61%	2 Safeway-65% Bakery-39%	7
Pkg. Liquor	2 Liquor stores-65%	2 Liquor-4% Wine-NR	1 Liquor-NR	1 Liquor-4%	1 Liquor-13%	7
Eat + Drinking Establ.	4 Deli-39% Rest w/L-13% Ice Cream-39% Pizza-22%	4 Deli-NR Rest w/L-17% Ice Cream-30% U-Bake Pizza-17%	4 Deli-NR Rest-Chinese-NR Rest-BBQ-NR Pizza-NR	1 Deli-13%	2 Yogurt-35% Pizza-22%	15
Home Furnishings + Appliances	1 Pool+Patio-22%	1 Boutique-4%	-	1 Interiors-NR	-	3
Bldg. Materials	-	1 Hardware + Nursery-70%	-	-	1 Hardware-26%	2
Auto Services	1 Repair-17%	-	-	1 Repair-4%	-	2
Gas Stations	1 Beacon-70%	1 "76"-4%	2 Chevron-NR "76" -NR	-	1 Shell-17%	5
Other Retail	4 Bike Shop-22% Photo Pickup-52% Pet Supplies-30% Video-30%	6 Florist-17% Jewelry-4% Art Gallery-9% Picture Frames-9% Cameras-22% Video-26%	3 Florist-NR Pet Supplies-NR Video-NR	-	6 Bike Shop-17% Uniforms + Med Supplies-4% Bottle Water-26% Sewing Supplies-13% Cards-35% Video-13%	19
Total Retail	<u>14</u>	<u>21</u>	<u>13</u>	<u>5</u>	<u>15</u>	<u>68</u>
Other Services	10 Travel (2)-13% Banks (2)-39% Realtor (2)-4% Tailor-9% Water Co-43% Cleaners-30% Insurance-8%	7 Travel-9% Banks (2)-4% Realtor-4% Cleaners-22% Shoe repair-22% Tanning-4%	7 Dance-NR Bank-NR Cleaners-NR Tanning-NR Beauty Shop-NR Nails-NR	4 Travel-NR Insurance-NR Cleaners-NR Beauty Shop-NR	6 Travel-9% Banks (2)-26% Post. Off.-43% Beauty Shop-4% Cleaners -13%	34
Vacancies	<u>3</u>	<u>2</u>	<u>-</u>	<u>1</u>	<u>3</u>	<u>9</u>
Total Establish.	27	30	20	10	24	111

Note: NR = No Response  
 Source: Field Survey, Donald A. Wolfe & Associates

TABLE V - SUMMARY - EXISTING LAND USES - LOYOLA CORNERS - 1990

<u>Land Uses</u>	<u>No. Estab.</u>	<u>Parcels (Sqft)</u>	<u>Bldgs (Sqft)</u>	<u>% Total Space</u>
Retail Stores	14	106,900	43,600	48%
Retail Services	10	27,500	8,000	9%
Offices	(2 bkdgs)	144,000	28,100	31%
	<hr/>	<hr/>	<hr/>	<hr/>
Subtotal	24 Establ.	278,400	79,700	88%
Vacant and New Construc.	(3 bldgs. + one addition)	39,500	11,300	12%
	<hr/>	<hr/>	<hr/>	<hr/>
Total	24 Establ.	317,900	91,000	100%



TABLE VI SUMMARY - LAND USES IN LOS ALTOS SHOPPING AREAS

Shopping Area	Land Area (SF)	Buildings (SF)		Total	Retail % Total	Overall FAR
		Office	Retail			
Downtown	2,126,436	572,669	488,933	1,061,933	46%	.50
Rancho	254,550	13,697	65,797	78,494	84%	.31
Loyola Corners	511,939	86,638	82,638	169,276	49%	.33
Woodland Plaza	315,524	35,610	50,370	85,980	59%	.27
Foothill Plaza	580,665	3,575	105,542	109,117	97%	.19

Note: FAR = Floor Area Ratio

Source: Los Altos General Plan, Land Use and Buildout Analysis, 1987 (Note: The area and building square footages for Loyola Corners include a larger area than is used for this study.)

TABLE VII

## POTENTIAL EXPANSION OF STORES AND SERVICES - LOYOLA CORNERS

Type of Store/Service	Neighborhood Interest	Potential for Growth		Compatible w/ Area	Overall Outlook
		Nat'l.	Area		
Apparel					
Women's	Low	Low	Mod.	Yes	Good
Family	Low	Low	High	Yes	Good
Children	Low	Low	Mod.	Yes	Good
Sports	Low	Low	Mod.	Yes	Good
				Special opp.	
Gen. Merchandize					
Dept/Variety	Low	Low	Mod.	No	No
Drug Store					
Pharmacy	Low	High	Low	Possible	Possible
Food					
General Mkt.	Low	Mod.	Low	No	No
Produce Mkt.	Low	Low	Low	Special opp.	Good
Bakery	Low	Low	Mod.	Special opp.	Good
Dairy Products	Low	Low	High	Yes	Good
Eat and Drink					
Small Rest.	High	Low	Low	Special opp.	Possible
Fast Foods	Low	High	High	No	No
Drinking	Low	Mod.	High	No	No
Home Furnishings					
Boutiques/Gifts	Mod.	Low	Low	Yes	Not Likely
Antiques	Low	Mod.	Low	Yes	Not Likely
Bldg. Materials					
Garden nursery	Low	Low	Low	Yes	Not Likely
Hardware	Low	Low	Low	Yes	Not Likely
Auto Services					
Service Station(Full)	Mod	Low	Low	Possible	Possible
Parts	Low	High	High	Yes	Good
Other Retail					
Books/Mags	High	Mod.	Low	Yes	Not Likely
Copy/Office	High	Mod.	Low	Possible	Possible
Cameras	Low	Low	Low	Yes	Not Likely
Electronics	Low	High	Low	Yes	Not Likely
Toys	Low	Low	Low	Yes	Not Likely
Sports Equip.	Low	Low	Low	Yes	Possible
				Special opp.	
Retail Services					
Beauty	High	Low	Low	Yes	Not Likely
Barber	High	Low	Low	Yes	Not Likely
Bank	Low	Low	Low	Yes	Not Likely
Cleaners	Mod.	Low	Low	Yes	Not Likely
Shoe Repair	Mod.	Low	Low	Yes	Not Likely
Other Repair	Low	N.A.	High	Yes	Good
Other Services					
Full Post Office	High	Low	N.A.	Special opp.	Possible
Community Ctr.	High	Mod.	N.A.	Special opp.	Possible

Sources: Community Meetings and Surveys, Interviews with Community and Business Leaders, Commercial Market Report prepared for City of Los Altos, Urban Land Institute data, Donald A. Wolfe Associates.

APPENDIX C

**Citizen Input On Loyola Corners' Study**

Questionnaire and 9-28 Public Meeting

Results per category

Number of responses

Meeting

Questionnaire

**1. QUESTION: Have you any suggestions for design changes, etc....?**

No comment		44
No change - leave as is	20	10
Design changes desired:		
<b>A. Act only with professional overall plan</b>	4	
<b>B. Character and style</b>		
<b>I. Overall village character</b>		17
Preserve heritage	1	
Not modern	1	
Small town look - neighbor hood feeling	3	17
Uniform design and color		17
Walking mall with parking on perimeter	3	7
Perimeter parking		1
Courtyard for walking, art shows		1
Walking spaces for neighbors		1
Pool, pond - provide water sounds, access	1	
Street gas lamps		1
Buildings look more like residences	1	2
Old-fashioned charm - quaint, classy, not "cutsy"		1
Old-fashioned street lights		2
Simple	1	
Neighborhood-type stores	2	
No weird sculptures	1	
<b>II. Adobe Look</b>		4
Spanish design		1
Stucco walls		1
Mexican or Italian accents		1

Number of responses

Meeting      Questaire

III. Early Californian		17
Earthy colors	1	
Cliff May (architect)		1
Old train station notif		1
As the area used to be		3
IV. Town and Country / Rancho Look		9
Not Rancho look	1	

**C. Miscellaneous Suggestions**

I. Walkways

More pedestrian walkways, bicycle paths, benches	11	8
--	----	---

II. Lighting

No flashing signs		5
Better lighting in parking area		3
Signs / kiosks at entrance of Loyola Corners	1	
Strict regulation on signs	3	
Coordinate lighting, curbs, stores for ease of use	2	

III. Change

Nothing that attracts crowds, liquor	1	
Stop / postpone current condo project	5	
(a) Postpone until traffic study complete	1	
Reduce early AM noise from Post Office	1	
Post Office is an eyesore - eliminate it	2	2
Relocate / remove chain link fence at post office	12	
Open full service post office	14	3
Update store fronts		4
Refurbish store interiors	1	

**Number of responses**

**Meeting**      **Questaire**

**IV. Stories**

Single story only		11
Two stories	3	6
First story retail / second story residential		4

**V. Rezone**

No higher density	1	1
Eliminate shops in residential areas		3
Rezone for apts / condos		1
Eliminate current mix		5
Promote rezoning to R-1	2	
Make Loyola Corners a park	1	

**2. QUESTION: What types of landscaping would be appropriate?**

No comments 55

Landscaping comments:

Not main issue of Loyola Corners 2

**I. Landscaping Design Themes and Suggestions**

Landscaping should reflect the history of the community		1
Comparable and similar to downtown, as much color and trees as possible		1
Similar to Rancho		1
Remember historical creek		1
Country village		1
Victorian look		1
Cobble stone accents		1
Keep in mind Festival of Lights and create low trees Pistachio	2	1

Number of responses

Meeting

Questaire

II. Materials to Utilize

A. Shrubs

Native to California		1
Low shrubs		8
Drought resistant		7
Oleander		1
All around buildings		1
Easy- upkeep		1

B. Trees:

Need more trees		35
Mix evergreen and deciduous		3
Reflect history of the community		1
Keep large trees wherever possible, especially along Dolores	1	3
Native Californian	2	
Pistachio - like downtown		1
Drought resistant		1
Here and there - no big deal		1
Equally in front of buildings as well as parking lots		1
Extensions of carob trees lining Carob Lane and Dolores might tie area together		1
Remove Carob at Miramonte and Dolores	1	
No palm trees	2	1
Sycamores	2	
Smog resistant	4	
Shade trees	1	

C. Flowers

Potted flowers and plants		17
Seasonal flower beds like downtown	1	

Number of responses

Meeting

Questaire

D. Grass

Must have to break up impact of all the asphalt		1
Use grass burms as on El Camino		1

E. Miscellaneous

Keep bushes trimmed so signs are visible	1	
Pots, window boxes, benches, brick walks		1
Use large potted groupings of flowers and trees trellis, vines, hanging plants		1
Trees along 2-way Fremont with no parking and bike lanes	1	
Tiles and landscaping along Miramonte as a buffer	2	

F. Mini-parks, greenbelts

Set the buildings back visually with strip parks		1
Move Photo Drive-up and make into green area with mounding	1	1
Put Loyola Corners entry sign		1
Green area could be tied to pendenstiran bridge over Permanente Creek		1
No landscaping between cars in parking area	1	

G. Suggestions for existing buildings

Post Office - look "like a Bulgarian Embassy"	15	1
Update zip code sign on Post Office	1	
Downey Savings - OK		1
Older stores - need planters, trees		1

Number of responses

Meeting

Questaire

**3. QUESTION: Do you have suggestions for parking improvements?**

No more parking needed 12  
No comment 73

I. Parking spaces - Comments, additions or subtractions:

A. Relative to stores

Parking plaza behind stores 12 10  
Place parking plaza space behind stores 1  
Lots of trees, landscaping between rows 1

B. Parking area overbuilt already 1

Not enough parking spaces as is 1  
More buildings will add to already bad parking problem 1

C. Increase parking spaces availability 7

Make them "internal" parking lots, structures 1  
Especially not visible from streets - behind stores 1  
Combine B and Lorraine streets into parking lot 1  
Plan parking to meet increased demand from new businesses 2

D. Restrict parking from entering residential areas 11 1

E. Two story parking

Add at Bank of America 1  
Add at area behind stores 1  
Must be concealed by dense landscaping 1



	<u>Number of responses</u>	
	<u>Meeting</u>	<u>Questaire.</u>
F. Underground parking	11	16
Off Miramonte		1
Easily accessible from main streets		1
Now parking is fragmented and encourages illegal parking		1
No underground parking	13	
G. Post Office - Old Safeway		
Why does post office fence off all parking? Old Safeway lot handled excess parking.		7
Must require on-site - not street parking	2	1
Have post office provide same number of parking spaces as other commercial property		1
People are forced to park in front of neighbors' homes to get mail		1
Get rid of post office - then plenty of parking	2	1
If post office becomes full service, use parking between Echo and Water Co.	1	
Require post office employees and trucks to park behind building	1	
H. Miscellaneous suggestions		
Permit more parking on Fremont		2
Water Co needs other than street parking	1	1
Need more handicapped parking around area		1
More bike racks in front of stores		1
I. Problems to solve		
Have parking with time enforcement		1
Strengthen parking enforcement at the bus stop at corner of A Street and Fremont @ Mom's		1
Parking is too congested at Farmer's Market add bike racks - encourage biking there		1
Limit parking at curbs	3	

Number of responses

	<u>Meeting</u>	<u>Questaire</u>
Second overpass	2	3
Eliminate all left-hand turns onto F-Hill X-way		1
Prohibit right turn entry on x-way westbound	6	
Left turn onto bridge - improve visability		1
Fill Expressway to grade level		1
Eliminate bridge access from LAH	1	
Eliminate ingress/egress to reduce congestion from x-way	2	
 2. Photo Drive-Up		
Remove it	22	17
Make island more asscessible to pedestrians		1
Allow right turn onto Fremont from Photo DU		1
Enter from Fremont only, exit Miramonte only		1
 3. Traffic signs		
No more traffic lights		2
Remove low signs at Miramonte and A		2
Improve YIELD at Beason and Bank to STOP		1
Make light timing shortened in E-W direction		1
 4. Narrow streets		
Do not straighten streets		1
Make one-way streets		1
Eliminate A street		2
No on-street parking		2
Too many streets - consolidate into parking		4
Do not widen to ease access		1
Reroute bus traffic / move to Foothill	45	4
Add bicycle and pedestrian routes / crosswalks		6
Route bikes out of the area		1
To solve traffic jams at rush hour, see map (#1)		1
Reduce noise and traffic		1
Sound barriers at Foothill		1
Remove dip at Fremont Ave.		1
STOP sign - McKensie and Holly		1
LIGHT - Grant and Oak		1

5. Miramonte Avenue (MA)	<u>Number of responses</u>	
	<u>Meeting</u>	<u>Questaire</u>
A. Reduce high density use of MA		
Intracounty use a problem	8	1
Make MA unpopular to thru traffic	1	3
Stop sign at MA and Berry	7	7
Stop light at MA and Covington	1	
Stop light at MA and A by Echo	1	
Stop sign at MA and Elaine	7	
Dead end MA near Fremont at Photo DU	7	1
Make Photo DU a park	1	1
Creat circular traffic pattern around LC	11	3
Make MA 25 MPH along length	2	
Prohibit all trucks on MA	15	4
Shift traffic to Fremont and Foothill	1	1
B. Traffic flow at Loyola Corners (LC)		
	6	
Right turn lane on MA to A	1	
Improve access to LC - fewer alleys	2	
Stacking lane - widen between post office and Fremont	1	1
Improve signage and access and to and from MA - confusing	3	
Do no widen MA	12	
C. Other		
Reverse drive-way at JP	1	
No on-street parking, especially in front of PO	1	
Remove sharp turn off MA onto A street		

Number of responses

Meeting                      Questairs

6. Fremont Avenue

Widen to two-way	6	5
More traffic, less on Miramonte		1
Allow right hand turn from Foothill to Fremont		1
Vines on Fremont by Photo DU obstructs view going west		1
Add sidewalks / crosswalks to B of A		2
Change entrance and/or exit to Foothill from B of A	4	
Don't add to traffic		1
More parking on Fremont		1
Improve point from South Foothill to S. Fremont		1

7. Dolores Avenue

Slow speed of traffic	1	1
Reduce amount of traffic		1
Reroute bus off Dolores		2
Reroute traffic off Dolores		2
Speed bumps on Dolores		1

8. Covington Road

Too much traffic, add sidewalks		1
---------------------------------	--	---

9. Country Club side of bridge

Reduce number of streets	1	
Add round-about	1	

5. QUESTION: What types of businesses or services . . . ?

Keep it as is - no change	1	12
No comments		49

I. Specifically

Hardware store		2
Bookstore, mags, newspapers ( open evenings)	4	12
Smallish grocery store	4	12

Number of responses

	<u>Meeting</u>	<u>Questairs</u>
Shoe repair		4
Health food		1
Coffee shop - Open 8AM-Midnight	7	10
Ice cream shop		1
Bank		1
Liquor store		4
Convenience store-variety		3
Bakery	3	26
Botique and gifts	1	6
Open PO annex - PO service shop/office supplies		6
Restaurants		18
Breakfast, lunch-coffeeshop type		
Fish		
Italian		
Nice small / french		
Hobees		
Good Earth		
Country Gourmet		
Dennys		
Creekside coffee house/restaurant like N. Tahoe City		7
Pharmacy - full service	1	1
Large community center	2	5
Art, language	3	
Senior		
Dance hall for teens		
Civic building		
Electronics		
Flowers, fruits, veggies (yr. round farmer's mkts.)	1	11
Confestionary		2
Beauty parlor / barber	7	6
Cookie shop		2
Toy shop		1
Antique store		2
Clothing store		2
Stationery store	1	3
Dry cleaners (reasonable)		5
Pasta shop		2
Auto parts		1
Therapy / exercise / health center		1
Full service gas station	1	2

Number of responses

Meeting

Questaire

Buffering Suggestions Listed by Categories:

I. Buffer by returnnig to residential

1

5

II. Buffering by doing anything

Anything will improve visual effect. If arch.  
design is good, and parking and traffic im-  
proved, residents should be happy.

1

III. Buffering by traffic flow

Enforce 25 MPH speed limit - enforcement of traffic  
signs

2

Preference to low car traffic businesses

2

Divert flow of traffic thru or surrounding commerical  
area

1

Add bumps, dips as on Lundy, Granger, Arbor, Loyola  
and Frontero

1

Keep traffic flow on Foothill or Fremont

2

Improve traffic routing

1

Keep bridge neutral - no signs or decoration, etc.

1

IV. Buffering by erecting physical barriers

Add sound barriers of cement block

4

2

Contain commercial area with fenced boundaries

1

Add 10 ft. walls along Foothill covered with ivy

4

No 10ft. walls

2

Walls only around repair station open only ;to MA

1

V. Buffering by parking

Parking restrictions on residential streets

4

Have limited access from residential streets to LC

1

Insist on adequate on-site parking

1

Locate parking between residences and businesses

3

Number of responses

	<u>Meeting</u>	<u>Questaire</u>
Professional medical building	1	3
Take-out catering /gourmet packagedf foods		3
Camera shop		1
Small garden nursery		1
Theater		1
Cinema		1
Bar and lounge		1
No theater / cinema		1

2. Generally

Fewer the better because of additional traffic	3	4
Keep as is / already appropriate		12
Cross section of service type businesses, like L Meats		7
Supply and demand - whatever survives	3	1
Independent stores, owner operated		3
No major stores (national chains, fast foods)	3	8
Keep it low key for residents - of office complexes	1	12
Do nothing - fate of area sealed when Safeway left		1
Beacon - an eyesore	1	2
Don't need two video stores		2
Only retail, no offices, businesses, insurance, etc.		1
Nothing noisy - consider vacancy factor - no "cutsy"		1
Remove repair garage	1	
Two world's concept	3	
Colmmunity orientedf businesses	1	
Needs an anchor store	1	

3. Kudos

Keep Loyola Meats - excelent quality - love it	6
Pet/ vet - wonderful	1

6. QUESTION: How Should Neighbors be Buffered From Commercial Uses?

Don't do anythging - great as is	3	
No comments		79

		<u>Number of responses</u>	
		<u>Meeting</u>	<u>Questaire</u>
VI. Buffering by utilization of landscaping		1	32
Parks, lawns, trees, etc.			
Use burms to hide parking			
VII. Buffering by shape of construction - low key expansion			
One story shops, low-impact structures	1		4
Fix remote, dilapidated structures			1
No two story offices or second story windows looking neighbors			1
Judicial placement of windows on second story			1
Make it small, residential commercial, as is, resulting in no special need for buffering	1		11
Nothing "glitsy"			1
Establish commercial support area, not a commercial center			1
Let businesses do the buffering	1		
VIII. Buffering by zoning			
Rezone corner lot of MA and Dolores for uniformity	5		1
No commercial development north of center line of Dolores			1
Have both sides of Dolores commercial, no commercial on Lorraine			1
Zone to have wide buffer zones between residential and commercial - wide setbacks	1		4
Develop transition areas between commercial and residential			2
No setbacks, Rancho has none	1		
IX. Buffering by wide sidewalks, walkways, and bike paths		1	2
Cement sidewalks in some areas	1		2
Bike paths and walkways			1
No sidewalks on residential streets			1
Sidewalks and trees on Dolores	4		
X. Buffereing by design			
Built for locals, not offices that bring in more traffic	1		1



	<u>Number of responses</u>	
	<u>Meeting</u>	<u>Questaire</u>
Light, commercial use, services, businesses not catering to youth		1
Peripheral businesses - no deliveries, medical, dental		1
Interior convenience stores		2
Limit commercial percentage and keep it ground level		1
Central plaza	1	1
Quiet, unobtrusive businesses		1
Buffer by returning it to residential-allows low cost housing, esp. for seniors		1
Limiting customers-no noisy customers		1
No deliveries to bldgs backing residences	1	

#### XI. Buffering by noise and light limitations

##### A. Light

Keep bridge "neutral" - no lights	1
Keep lighting to a minimum	1
No lighting on residential streets	1
Minimize lighting around business buildings, restaurants, etc.	1

##### B. Signage

Limit usage and lighting - especially during holidays	1
---	---

##### C. Garbage

Need more trash receptacles	1
Must limit pick-up times-no pickup at 4 AM	1

##### D. Noise

Buffer by limiting customers-no noisy customers	1
Limit post office noise in early hours	

DONALD A. WOOLFE AND ASSOCIATES



**DONALD A. WOOLFE, A.I.A., A.I.P.**

- Architecture
- Urban Planning

707 BRADFORD ST. SUITE D  
REDWOOD CITY, CA 94063  
(415) 366-2533